

SEZIONE 1

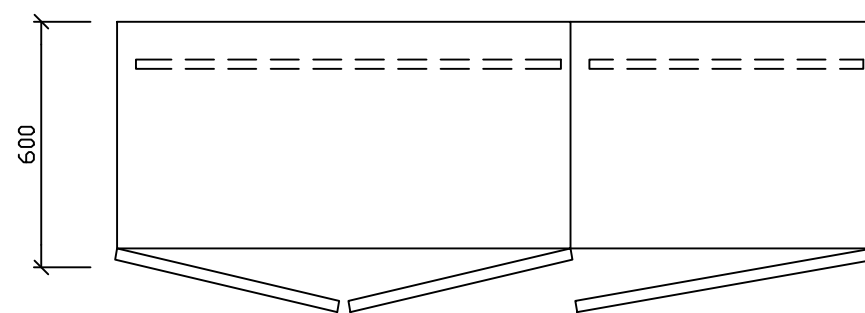

				DATA	04/03/2024		LAYOUT	REMOTO CARRO TRASFERITORE CC2		ACCIAIERIA	
				DISEG.	D.BILLE					NUM_ARCH: EAAC0745	
				VISTO						A348	A348.DWG
REV.	MODIFICA	DATA	FIRMA	APPR.		SOST. IL:	SOST. DA:	ORIGINE:			PREC. SEG.

A348

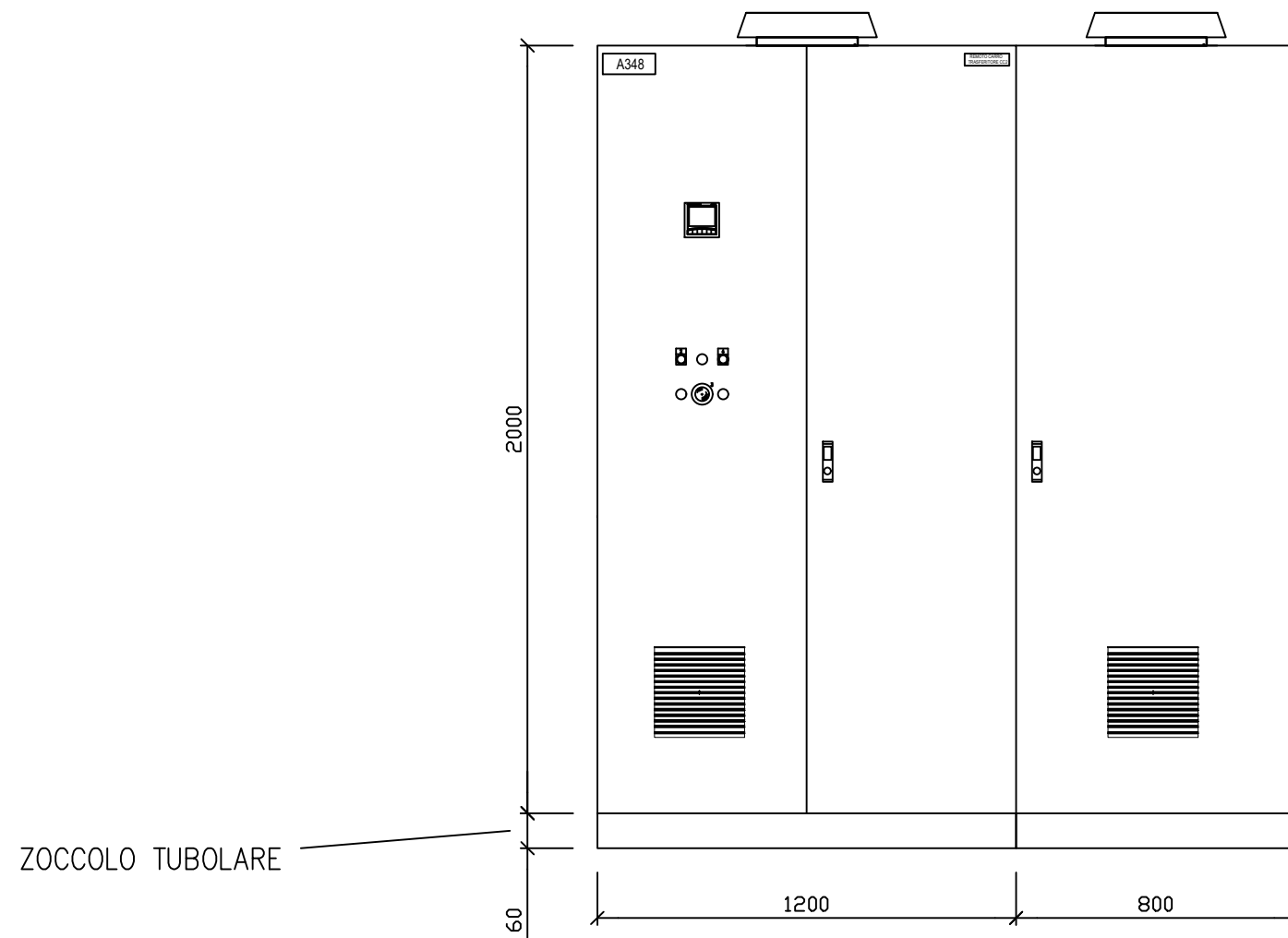
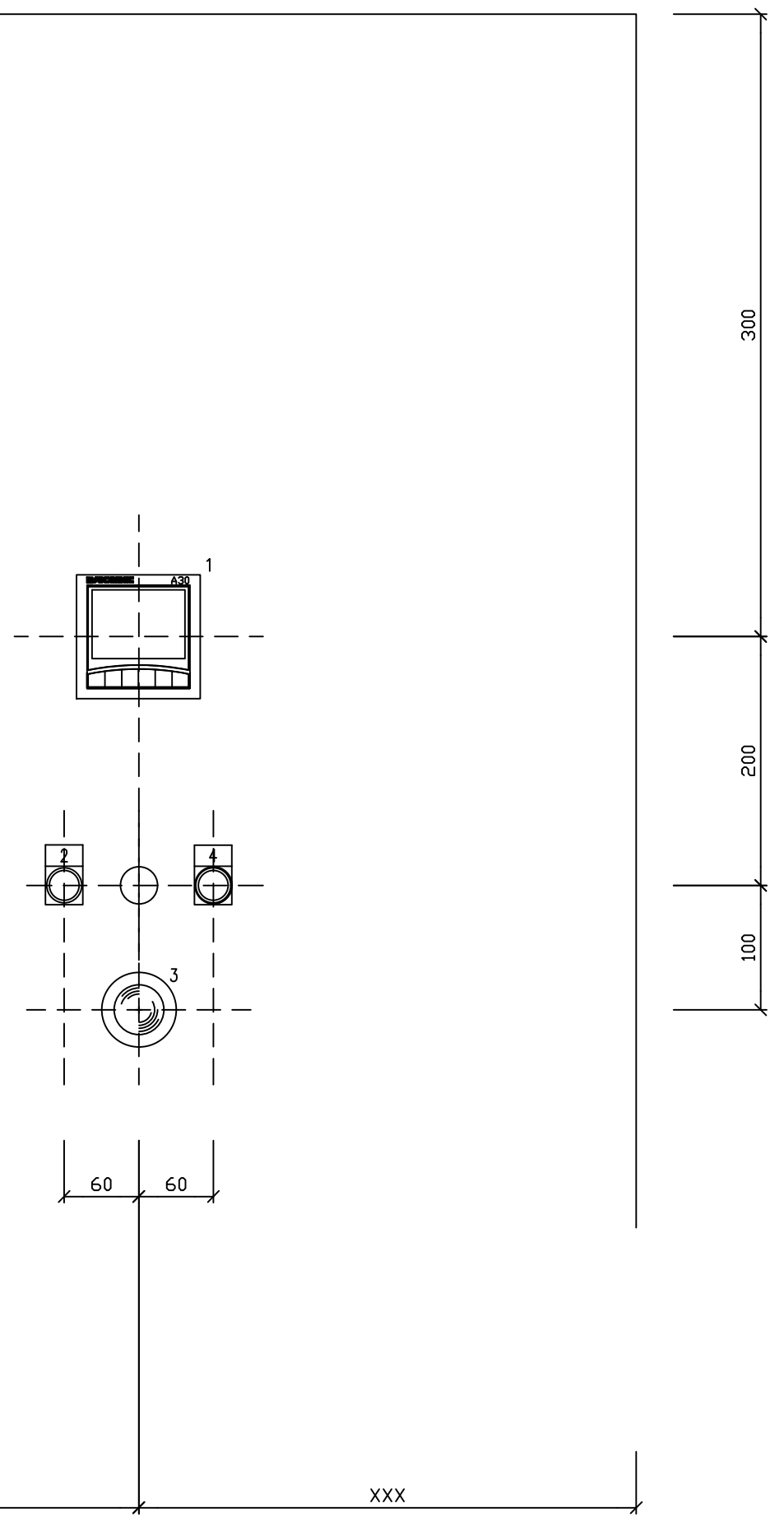

Pos.	Descrizione /Description	Tipo /Type	Des. T.N.F.
1	MISURE LINEA		33A06
2	RESET ALLARMI		309S04
3	EMERGENZA GENERALE		51S08
4	EMERGENZA ATTIVA		403H13
			...



Targa Tipo "TIE"

—————> T = Targa / I=Identificativa / E = Tipo "E"

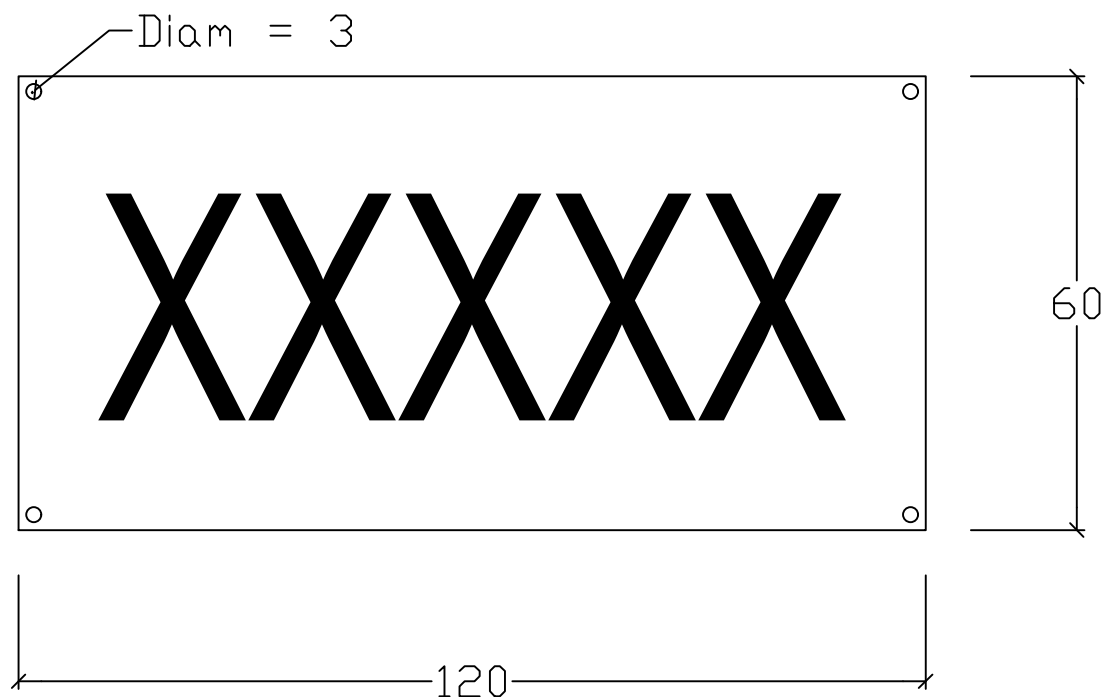

Note costruttive:

Targhetta PVC bicolore Bianco/Nero
 Testi Incisi e colorati (nero) con spessore carattere min. 3 mm
 Altezza testi : 30 mm

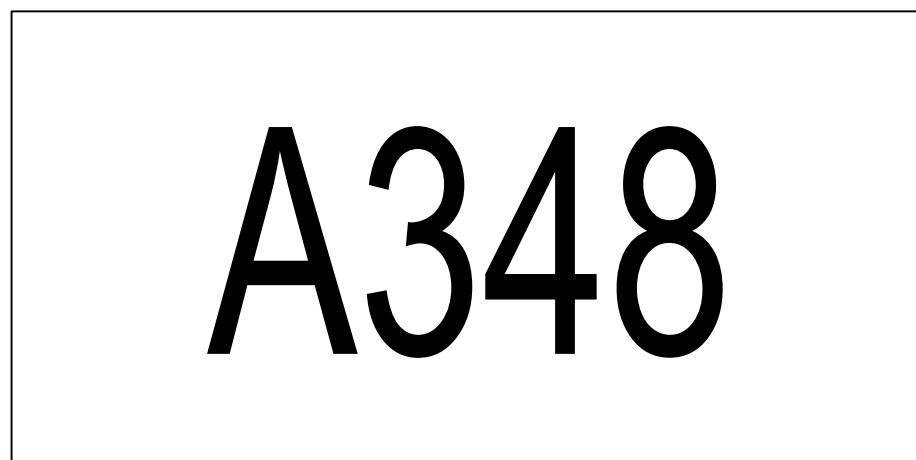

				DATA	04/03/2024	 ACCIAIERIE BELTRAME S.p.a.	TARGHE	REMOTO CARRO TRASFERITORE CC2		ACCIAIERIA	
			DISEG.	D.BILLE					NUM_ARCH: EAAC0745		FOGLIO 5 DI
REV.	MODIFICA	DATA	FIRMA	APPR.	SOST. IL:			SOST. DA:	ORIGINE:	A348	A348.DWG

Targa Tipo "TIF"

→ T = Targa / I=Identificativa / F = Tipo "F"

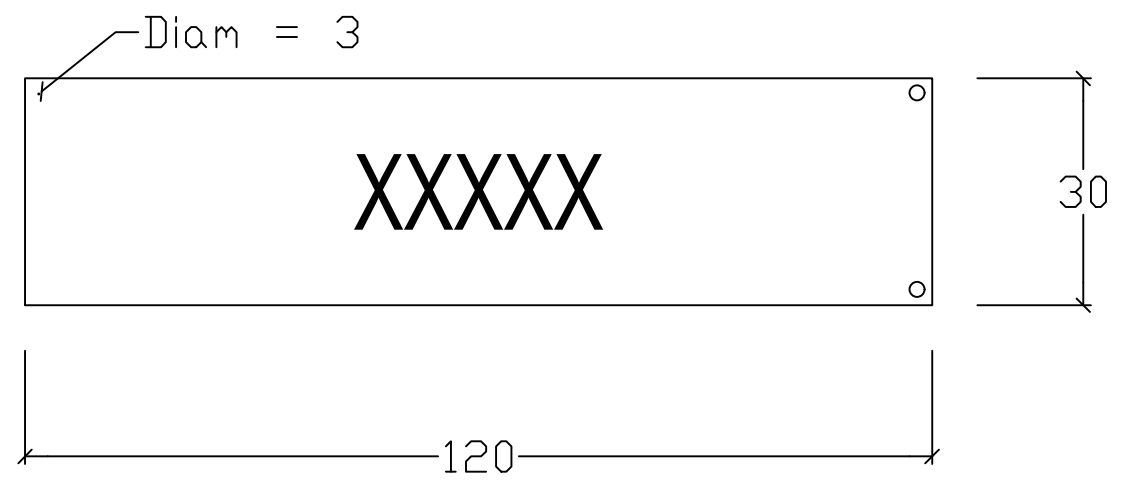

Note costruttive:

Targhetta PVC bicolore Bianco/Nero
 Testi Incisi e colorati (nero) con spessore carattere min. 1,2 mm
 Altezza testi : 10 mm

**REMOTO CARRO
 TRASFERITORE CC2**

				DATA	04/03/2024		TARGHE	REMOTO CARRO TRASFERITORE CC2		ACCIAIERIA	
				DISEG.	D.BILLE					NUM_ARCH: EAAC0745	
				VISTO						FOGLIO 7 DI	
REV.	MODIFICA	DATA	FIRMA	APPR.		SOST. IL:	SOST. DA:	ORIGINE:	A348	A348.DWG	PREC. SEG.

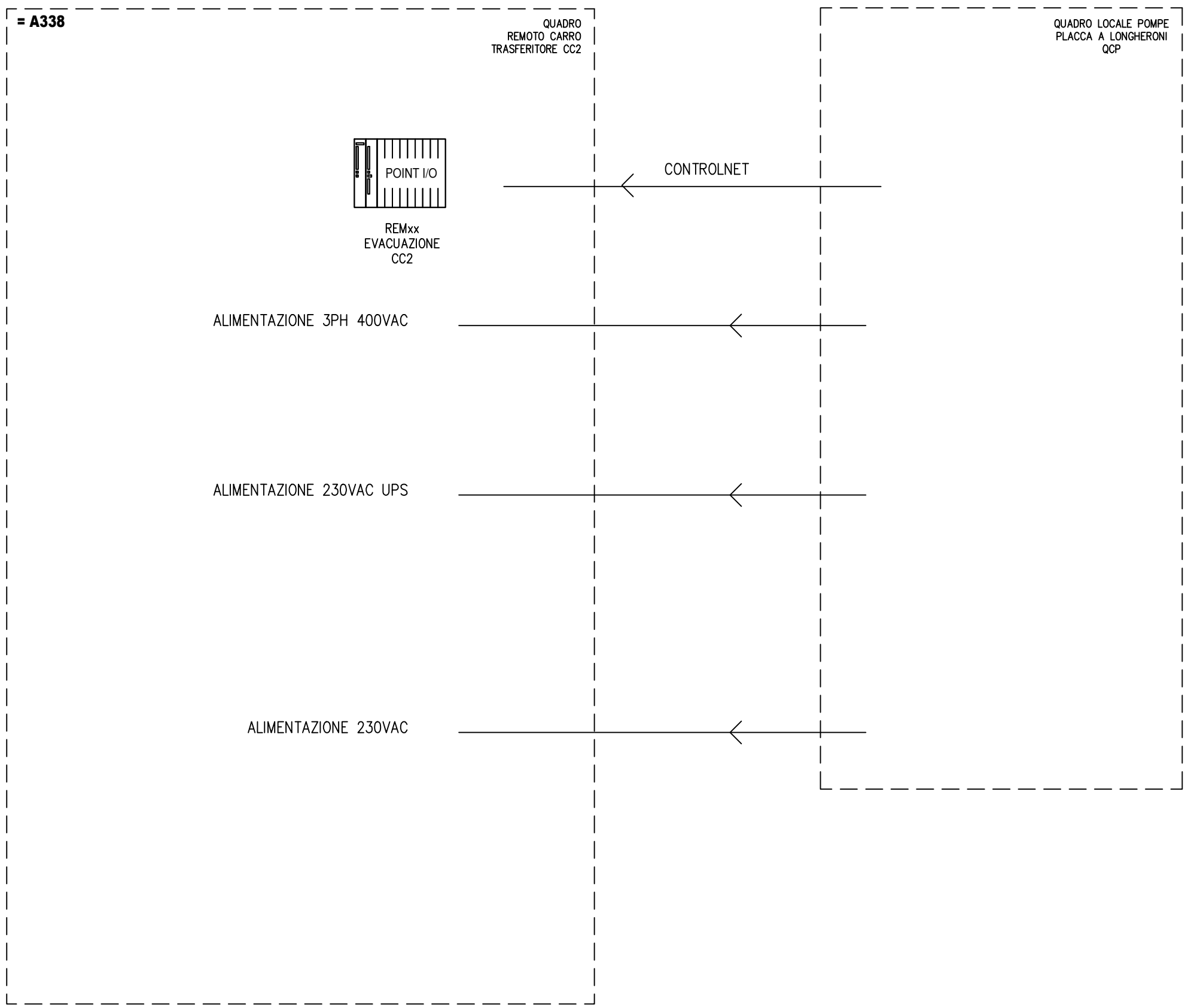

				DATA	04/03/2024		ARCHITETTURA DI SISTEMA		REMOTO CARRO TRASFERITORE CC2		ACCIAIERIA	
				DISEG.	D.BILLE						NUM_ARCH: EAAC0745	
				VISTO							FOGLIO 11 DI	
REV.	MODIFICA	DATA	FIRMA	APPR.		SOST. IL:	SOST. DA:	ORIGINE:	A348	A348.DWG		PREC. SEG.

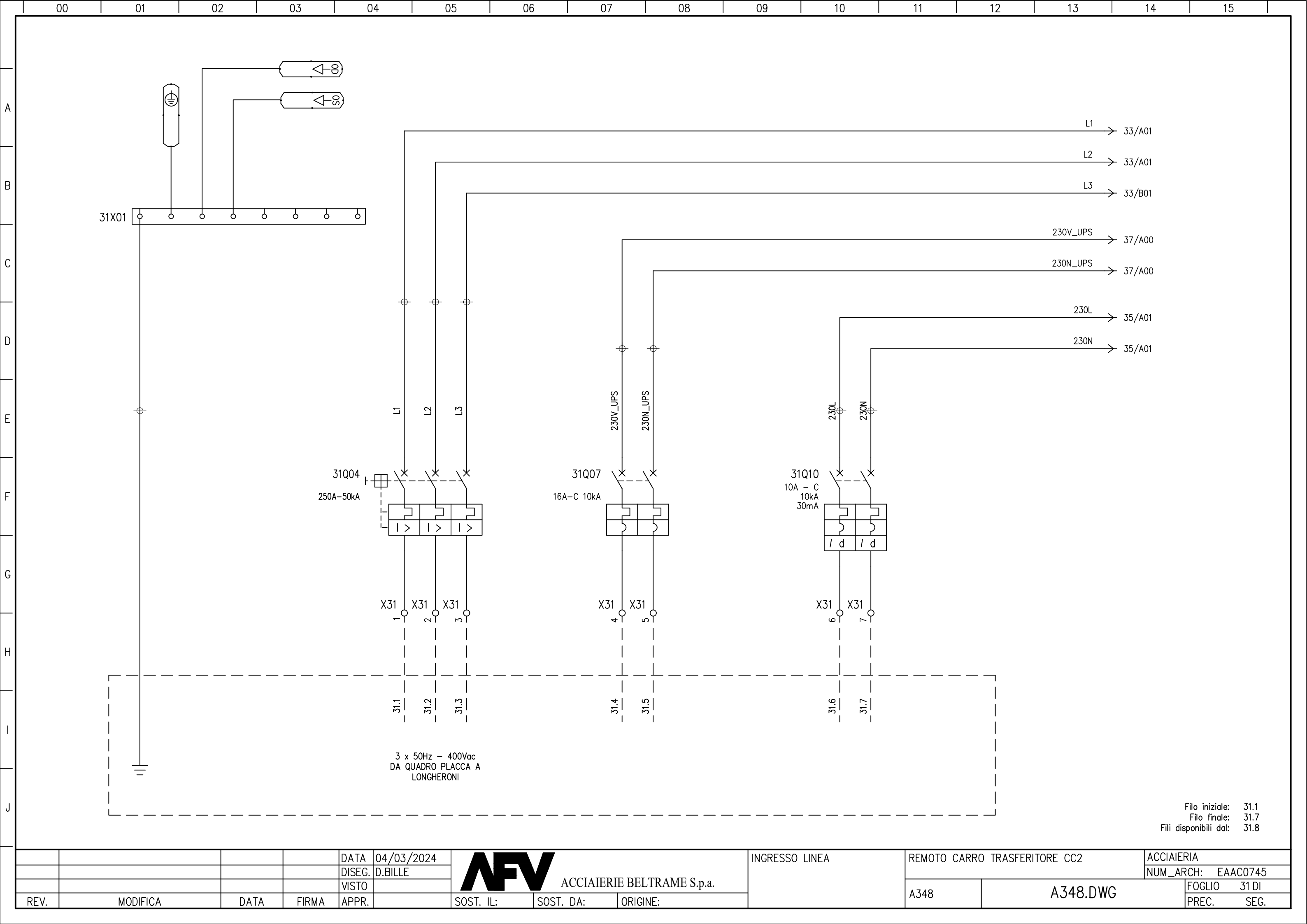

Filo iniziale: 31.1
 Filo finale: 31.7
 Fili disponibili dal: 31.8

				DATA	04/03/2024	AFV ACCIAIERIE BELTRAME S.p.a.	INGRESSO LINEA		REMOTO CARRO TRASFERITORE CC2		ACCIAIERIA	
				DISEG.	D.BILLE						NUM_ARCH: EAAC0745	
				VISTO							FOGLIO 31 DI	
REV.	MODIFICA	DATA	FIRMA	APPR.		SOST. IL:	SOST. DA:	ORIGINE:	A348	A348.DWG		PREC. SEG.

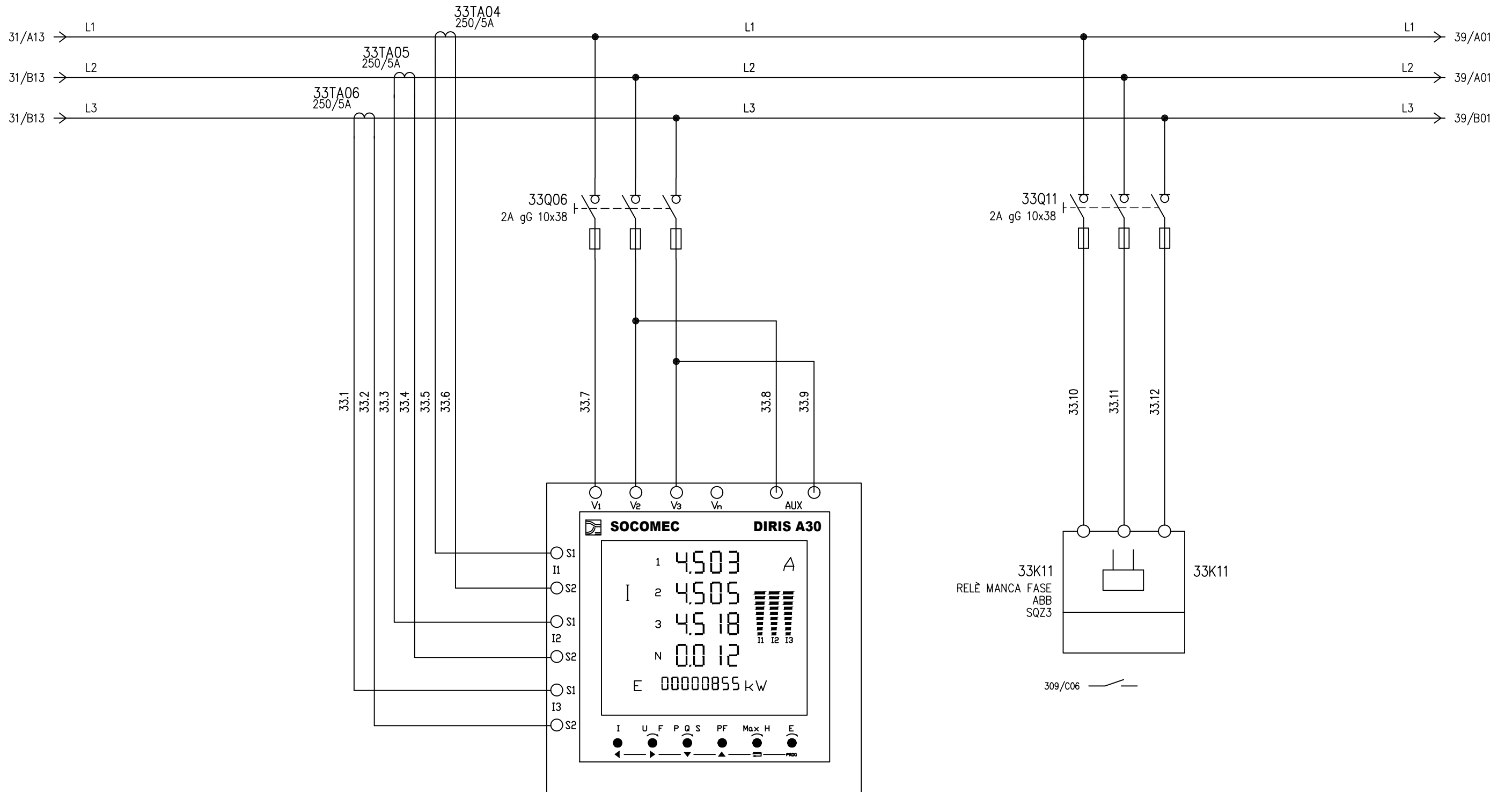

Filo iniziale: 33.1
 Filo finale: 33.12
 Fili disponibili dal: 33.13

		DATA	04/03/2024		MISURE	REMOTO CARRO TRASFERITORE CC2		ACCIAIERIA	
		DISEG.	D.BILLE					NUM_ARCH:	EAAC0745
		VISTO						A348	A348.DWG
REV.	MODIFICA	DATA	FIRMA	APPR.	SOST. IL:	SOST. DA:	ORIGINE:	PREC. SEG.	

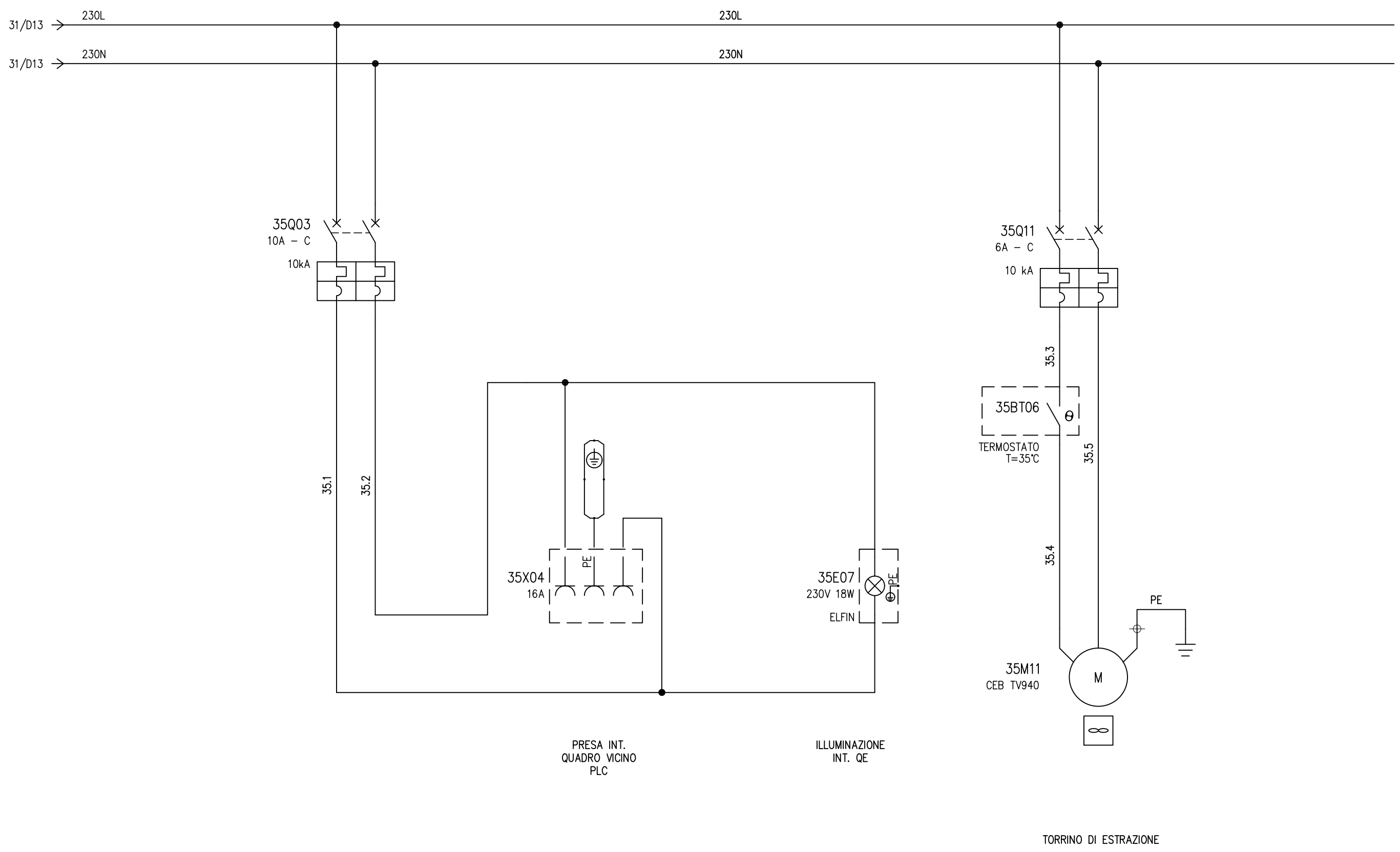

Filo iniziale: 35.1
 Filo finale: 35.5
 Fili disponibili dal: 35.6

REV.	MODIFICA	DATA	FIRMA	APPR.	SOST. IL:	SOST. DA:	ORIGINE:	ALIMENTAZIONI AUX. 230Vac	REMOTO CARRO TRASFERITORE CC2	ACCIAIERIA
										NUM_ARCH: EAAC0745
									A348	FOGLIO 35 DI
									A348.DWG	PREC. SEG.



A
B
C
D
E
F
G
H
I
J

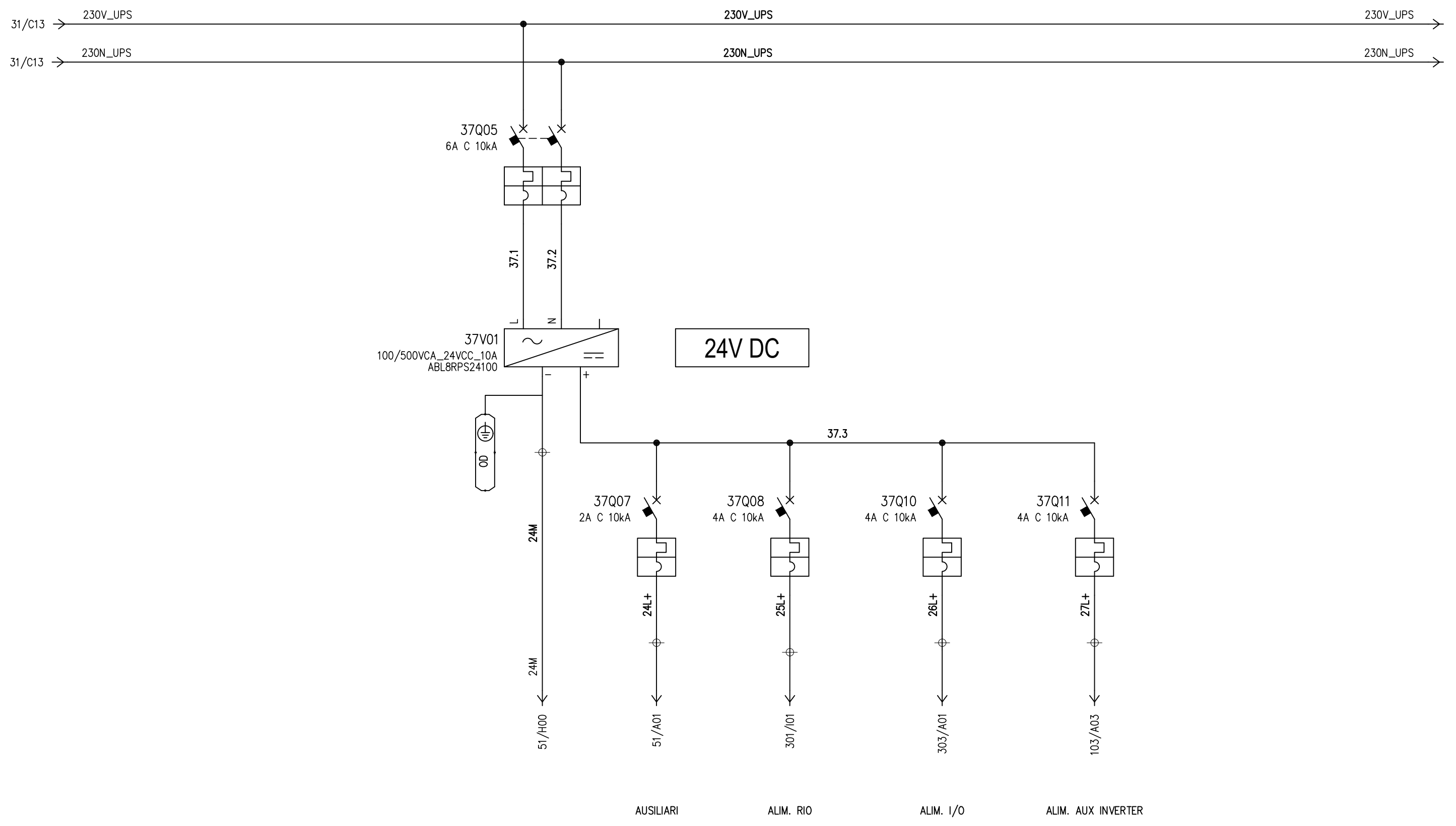

Filo iniziale: 37.1
Filo finale: 37.3
Fili disponibili dal: 37.4

REV.	MODIFICA	DATA	FIRMA	APPR.	DATA	04/03/2024		ALIMENTAZIONE AUX UPS	REMOTO CARRO TRASFERITORE CC2	ACCIAIERIA		
					DISEG.	D.BILLE					NUM_ARCH:	EAAC0745
					VISTO						A348	A348.DWG
					SOST. IL:	SOST. DA:	ORIGINE:			PREC. SEG.		

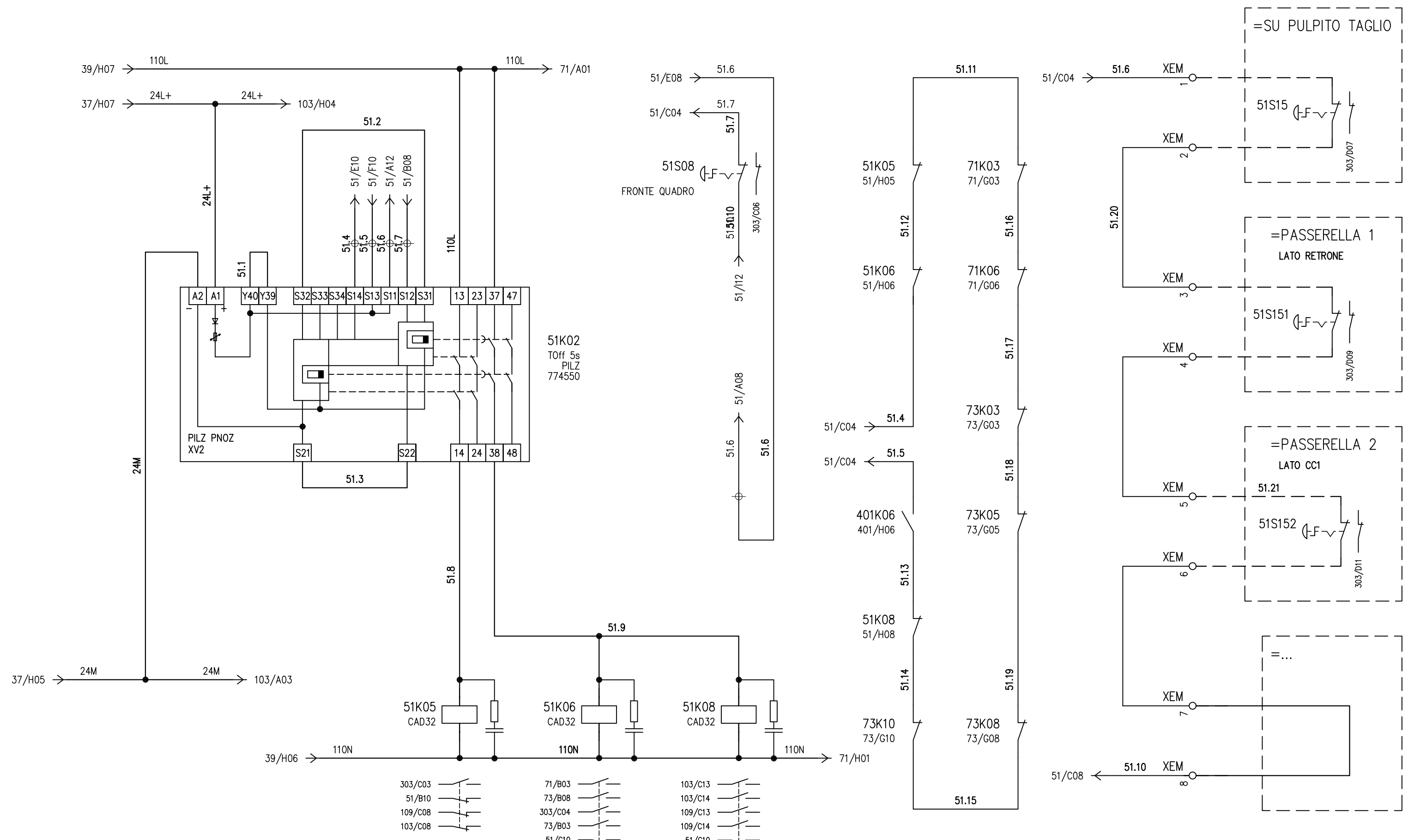

EMERGENZA EMERGENZA RITARDATA EMERGENZA RITARDATA

Filo iniziale: 51.1
Filo finale: 51.21
Fili disponibili dal: 51.22

REV.	MODIFICA	DATA	FIRMA	APPR.	DATA	04/03/2024	 ACCIAIERIE BELTRAME S.p.a.	EMERGENZE	REMOTO CARRO TRASFERITORE CC2	ACCIAIERIA	
					DISEG.	D.BILLE				NUM_ARCH: EAAC0745	
					VISTO			SOST. IL:	SOST. DA:	ORIGINE:	Foglio 51 DI
									A348	A348.DWG	PREC. SEG.

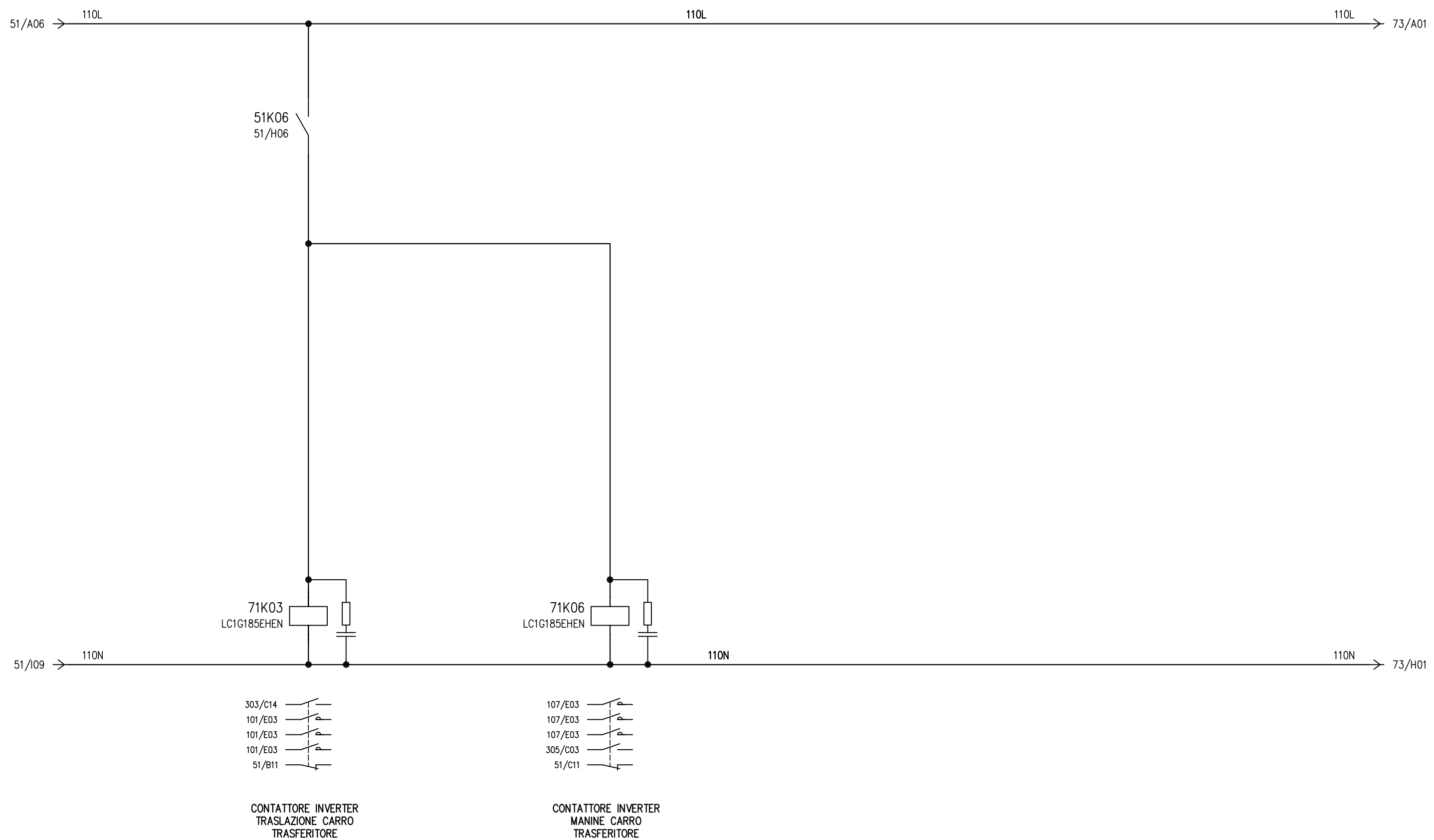

Fili disponibili dal: 71.1

				DATA	04/03/2024	 ACCIAIERIE BELTRAME S.p.a.	AUX 110Vac INVERTER	REMOTO CARRO TRASFERITORE CC2		ACCIAIERIA	
				DISEG.	D.BILLE					NUM_ARCH: EAAC0745	
				VISTO						FOGLIO 71 DI	
REV.	MODIFICA	DATA	FIRMA	APPR.		SOST. IL:	SOST. DA:	ORIGINE:	A348	A348.DWG	PREC. SEG.

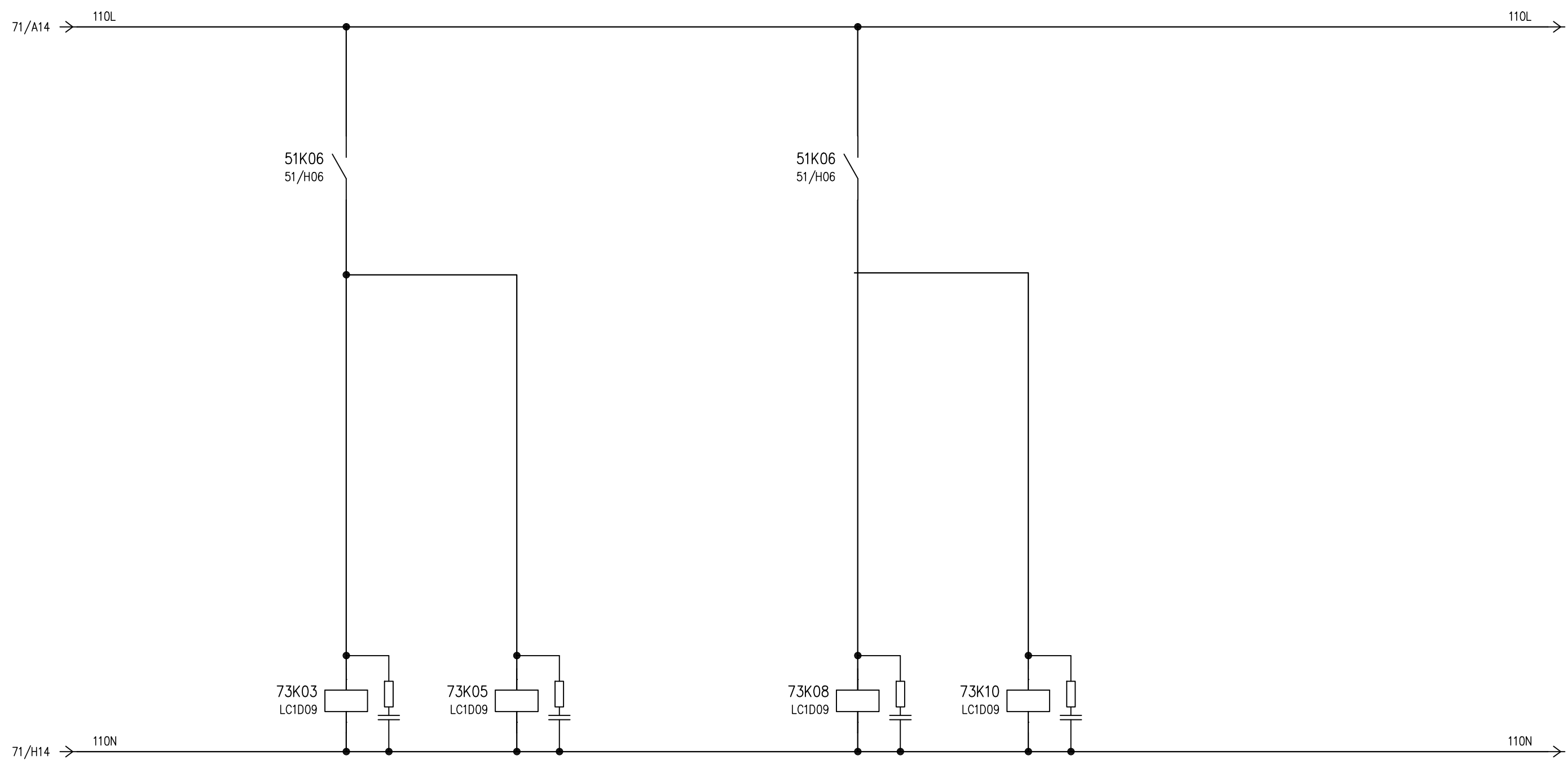

CONTATTORE FRENO TRANSLAZIONE DX **CONTATTORE FRENO TRANSLAZIONE SX** **CONTATTORE FRENO SOLLEVAMNETO DX** **CONTATTORE FRENO SOLLEVAMNETO SX**

				DATA	04/03/2024		AUX 110Vac FRENI	REMOTO CARRO TRASFERITORE CC2	ACCIAIERIA		
				DISEG.	D.BILLE				NUM_ARCH: EAAC0745		
				VISTO					FOGLIO 73 DI		
REV.	MODIFICA	DATA	FIRMA	APPR.		SOST. IL:	SOST. DA:	ORIGINE:	A348	A348.DWG	PREC. SEG.



ABB ACS880

ACS880-01-145A-3 +P944+K490+L502+D150
PN=75kW

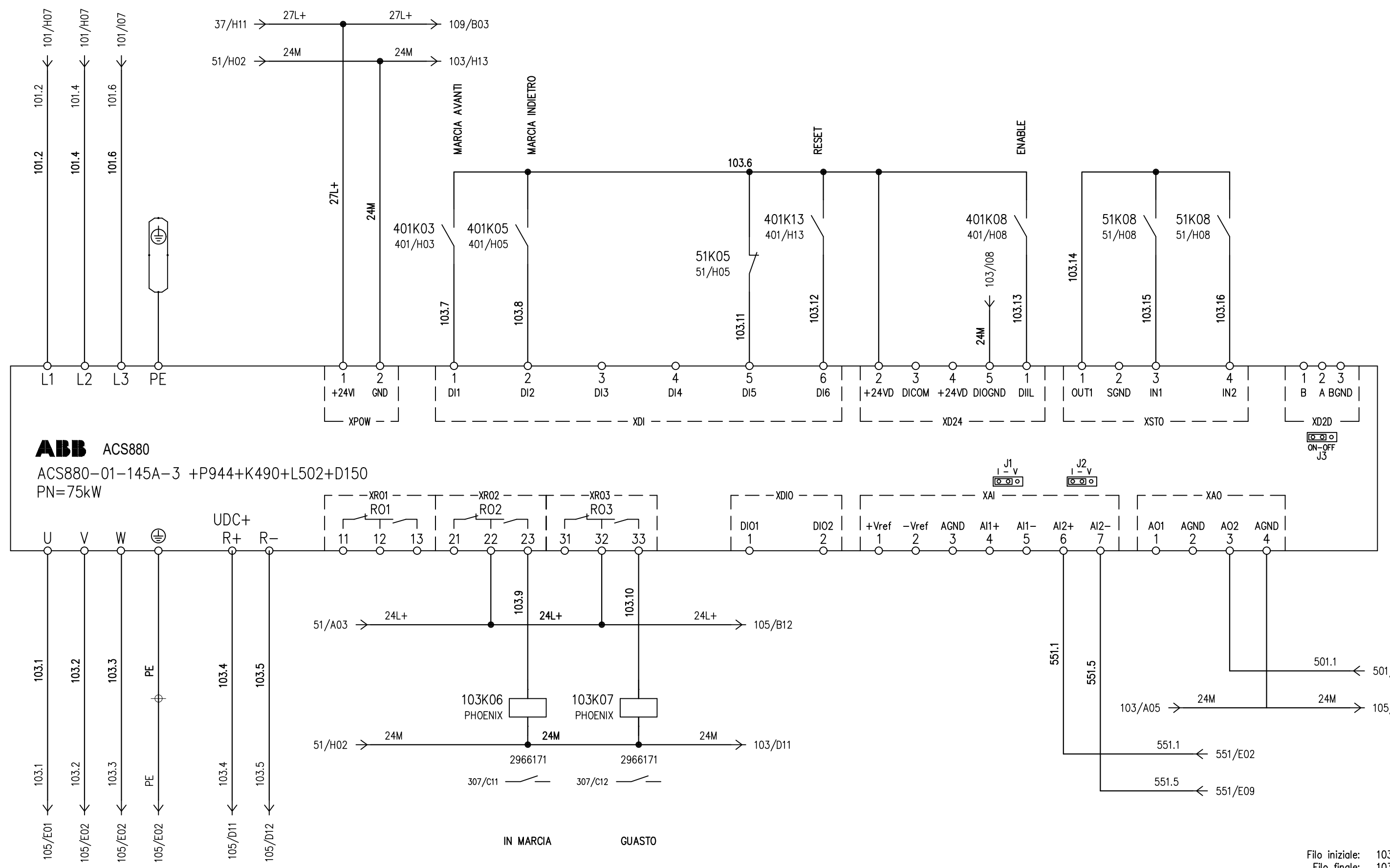

Filo iniziale: 103.1
Filo finale: 103.16
Fili disponibili dal: 103.17

DATA	04/03/2024	AFV ACCIAIERIE BELTRAME S.p.a.	INVERTER TRASLAZIONE	REMOTO CARRO TRASFERITORE CC2	ACCIAIERIA						
DISEG.	D.BILLE				NUM_ARCH: EAAC0745						
VISTO					FOGLIO 103 DI						
REV.	MODIFICA	DATA	FIRMA	APPR.	SOST. IL:	SOST. DA:	ORIGINE:	A348	A348.DWG	PREC.	SEG.

A
B
C
D
E
F
G
H
I
J

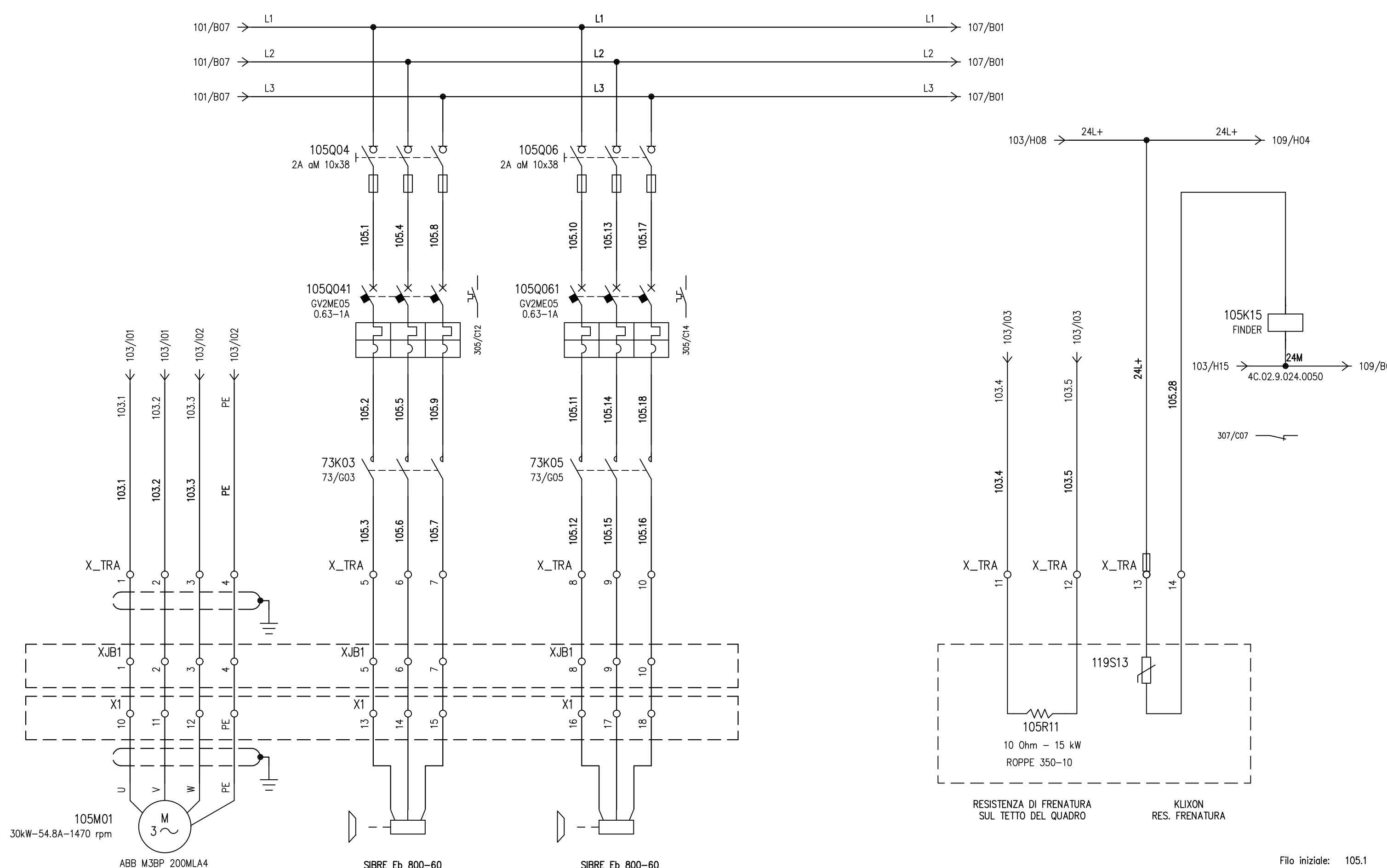

Filo iniziale: 105.1
Filo finale: 105.28
Fili disponibili dal: 105.29

				DATA	04/03/2024	AFV ACCIAIERIE BELTRAME S.p.a.	INVERTER TRASLAZIONE	REMOTO CARRO TRASFERITORE CC2	ACCIAIERIA	
				DISEG.	D.BILLE				NUM_ARCH: EAAC0745	
				VISTO					FOGLIO 105 DI	
REV.	MODIFICA	DATA	FIRMA	APPR.	SOST. IL:	SOST. DA:	ORIGINE:	A348	A348.DWG	PREC. SEG.



ABB ACS880

ACS880-01-145A-3 +K490+L502+D150+N5050
PN=75kW

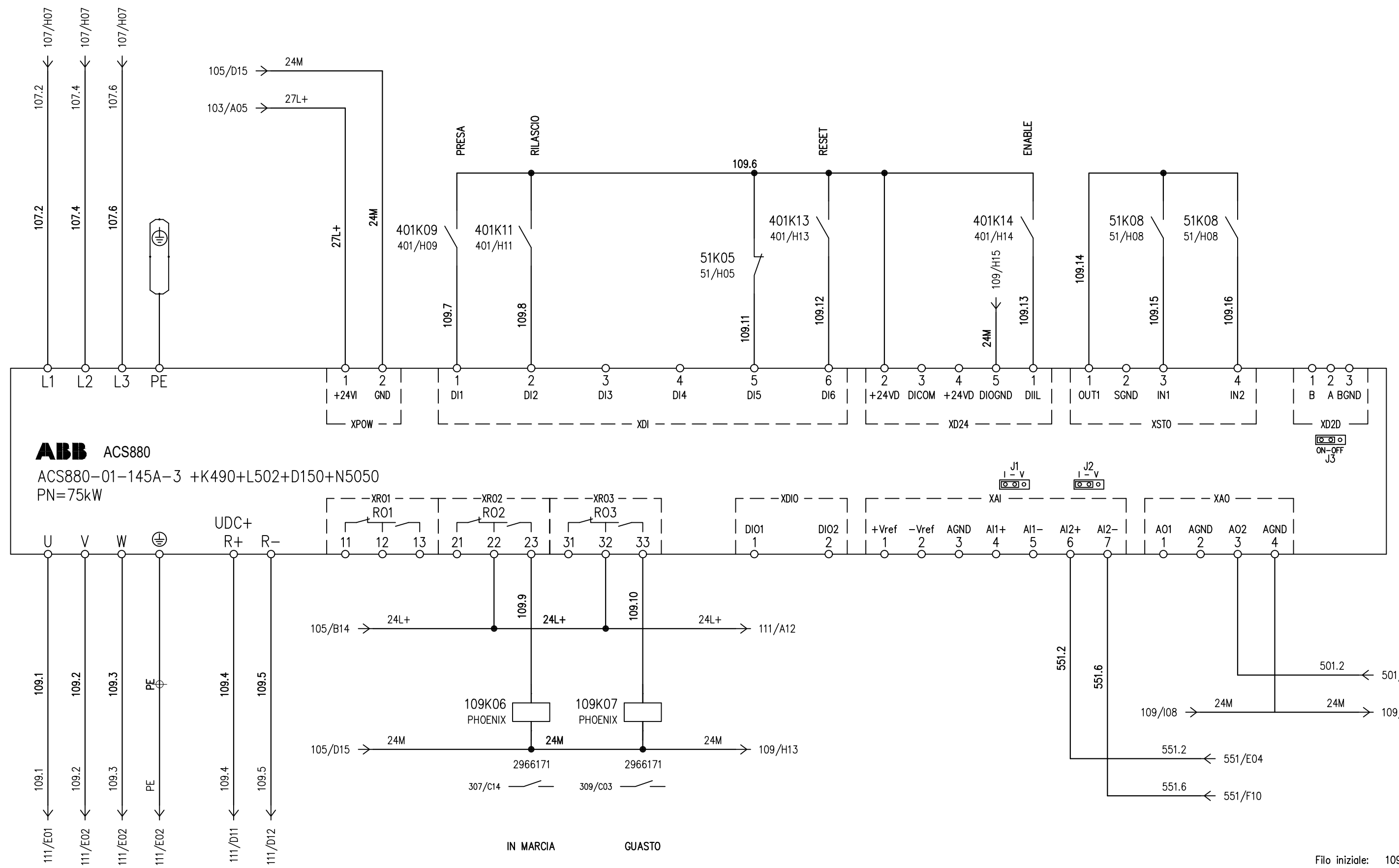

Filo iniziale: 109.1
Filo finale: 109.16
Fili disponibili dal: 109.17

REV.	MODIFICA	DATA	FIRMA	APPR.	DATA	04/03/2024	 ACCIAIERIE BELTRAME S.p.a.	INVERTER SOLLEVAMENTO REMOTO CARRO TRASFERITORE CC2	ACCIAIERIA NUM_ARCH: EAAC0745
					SOST. IL:	SOST. DA:	ORIGINE:	A348	A348.DWG
									FOGLIO 109 DI PREC. SEG.

A
B
C
D
E
F
G
H
I
J

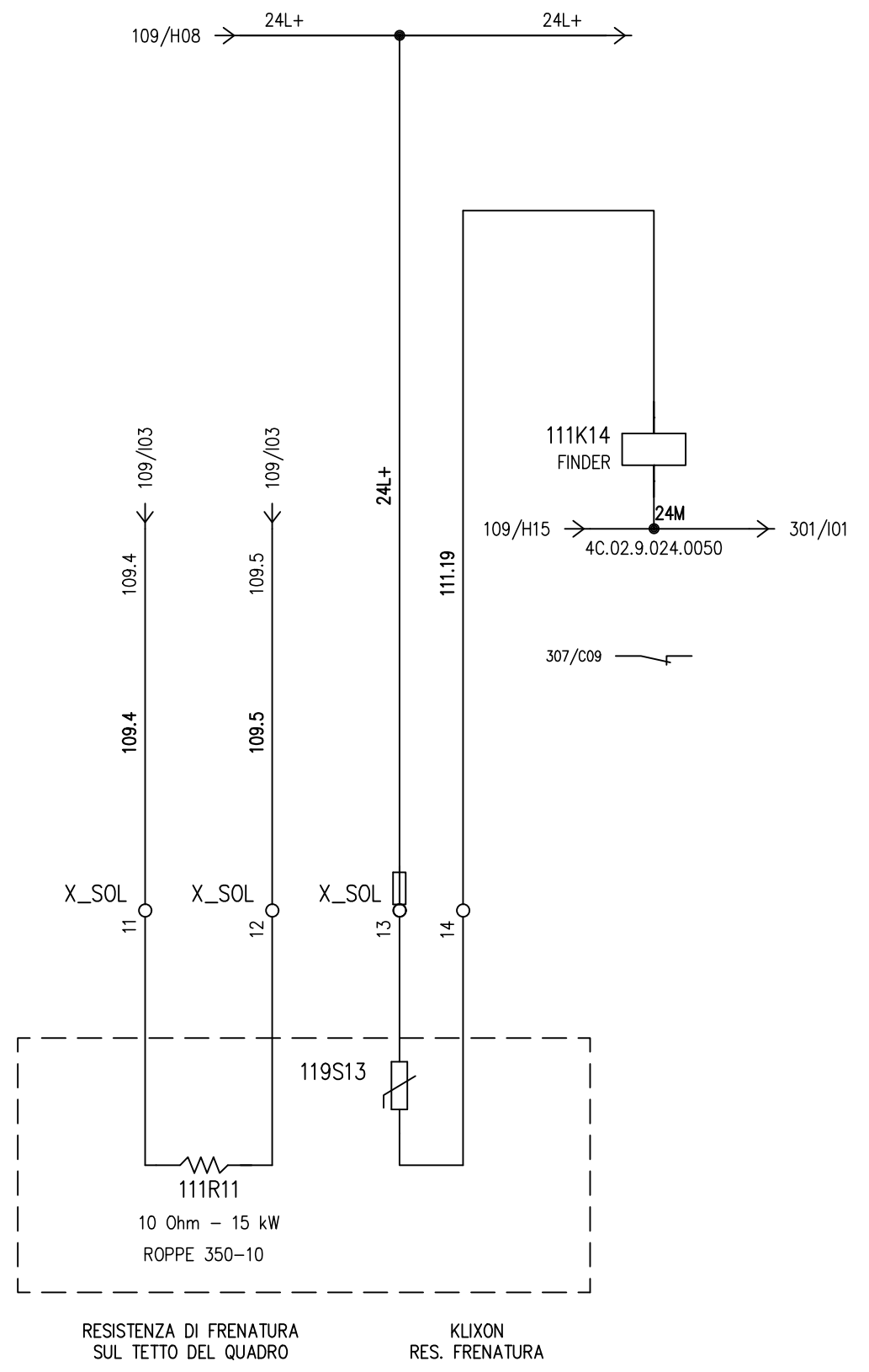
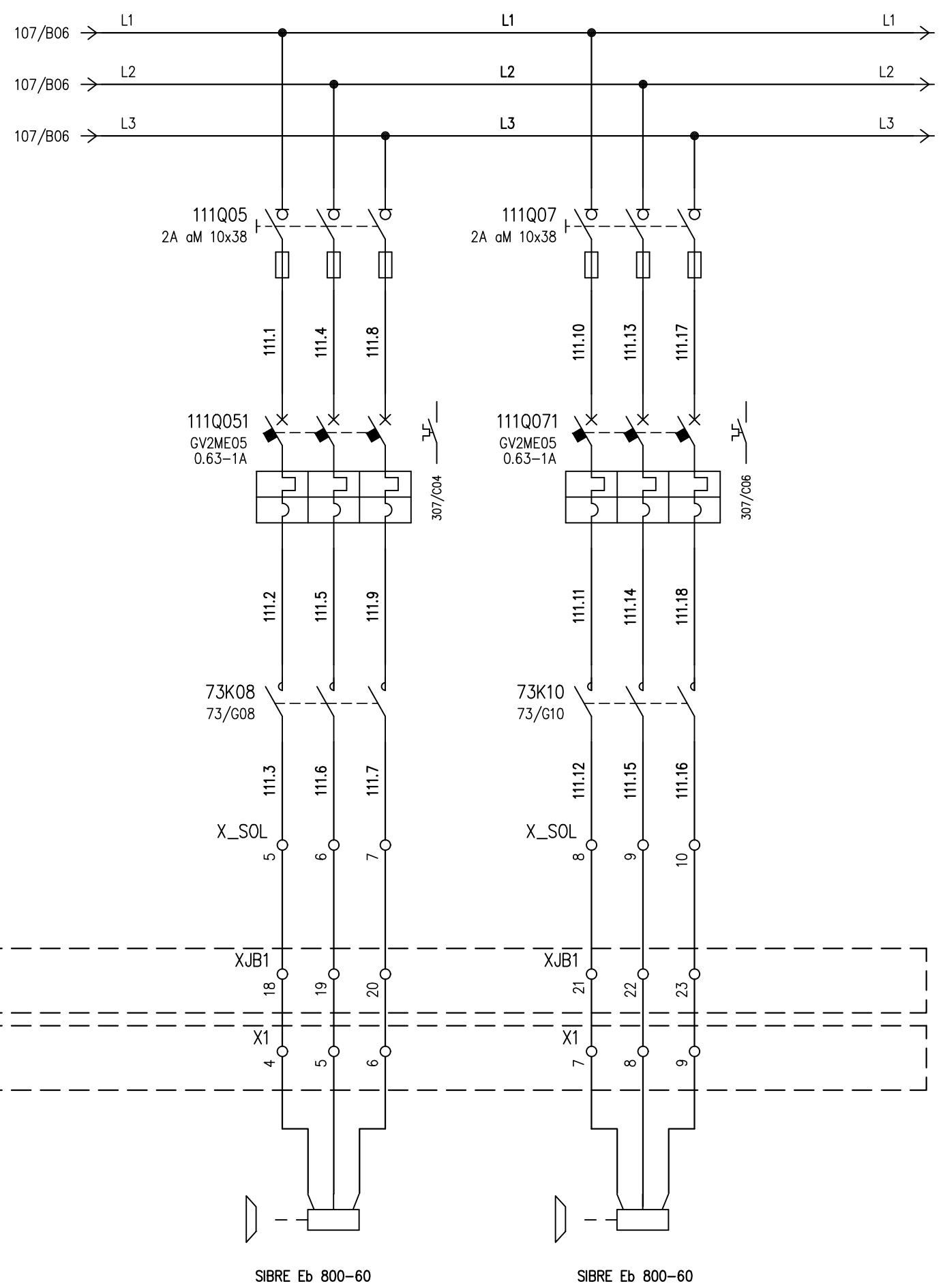

Filo iniziale: 111.1
Filo finale: 111.19
Fili disponibili dal: 111.20

		DATA	04/03/2024	AFV ACCIAIERIE BELTRAME S.p.a.	INVERTER SOLLEVAMENTO	REMOTO CARRO TRASFERITORE CC2		ACCIAIERIA	
		DISEG.	D.BILLE					NUM_ARCH:	EAAC0745
		VISTO						A348	A348.DWG
REV.	MODIFICA	DATA	FIRMA	APPR.	SOST. IL:	SOST. DA:	ORIGINE:	PREC. SEG.	

A
B
C
D
E
F
G
H
I
J

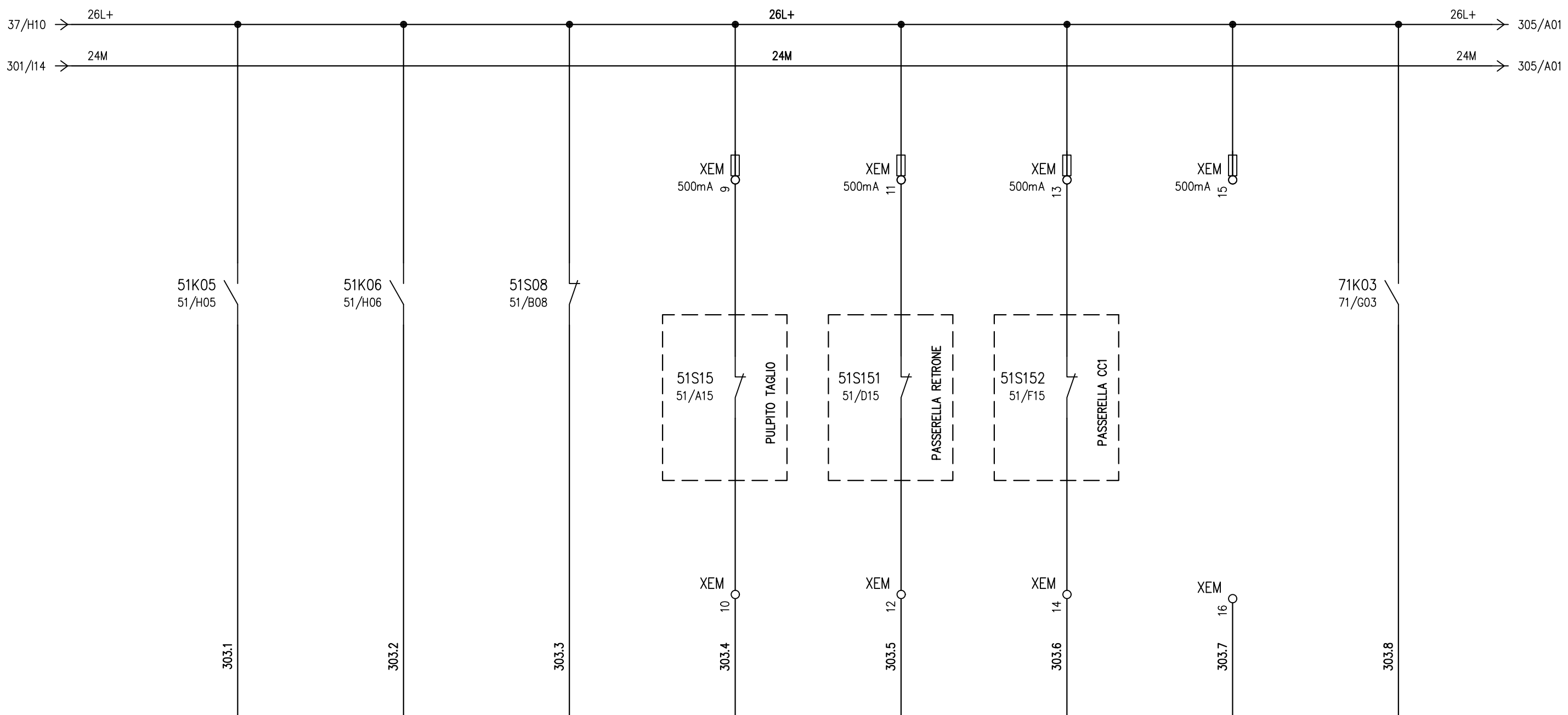

303A03	Pin	0	1	2	3	4	5	6	7
	Address	REMxx_1ID.0	REMxx_1ID.1	REMxx_1ID.2	REMxx_1ID.3	REMxx_1ID.4	REMxx_1ID.5	REMxx_1ID.6	REMxx_1ID.7
	Comment	FBK EMERGENZA Istantanea	FBK EMERGENZA RITARDATA	FUNGO SU QUADRO PREMUTO	FUNGO SU PULPITO PREMUTO	LATO RETRONE FUNGO SU PASSERELLA 1 PREMUTO	LATO CC1 FUNGO SU PASSERELLA 2 PREMUTO	LIBERO	INVERTER TRASLAZIONE CTO. FBK CONTATTORE
		OK=1	OK=1	OK=1	OK=1	OK=1	OK=1	OK=1	OK=1

Card :1734-IB8 [8x10-30 Vdc DIGITAL INPUT]

Filo iniziale: 303.1
Filo finale: 303.8
Fili disponibili dal: 303.9



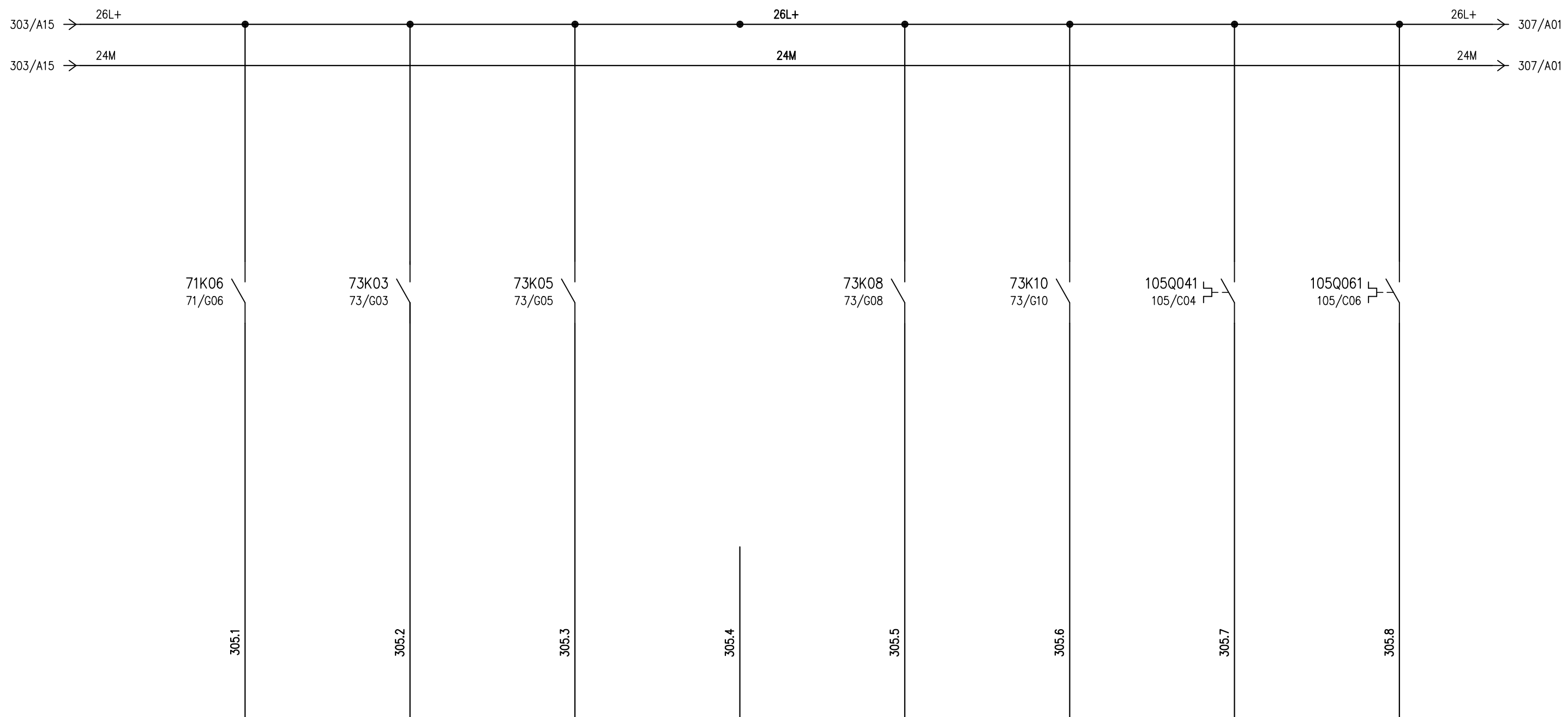

305A03	Pin	0	1	2	3	4	5	6	7
	Address	REMxx_2ID.0	REMxx_2ID.1	REMxx_2ID.2	REMxx_2ID.3	REMxx_2ID.4	REMxx_2ID.5	REMxx_2ID.6	REMxx_2ID.7
	Comment	INVERTER SOLLEVAMENTO CTO. FBK CONTATTORE	FRENO TRASLAZIONE DX CTO. FBK CONTATTORE	FRENO TRASLAZIONE SX CTO. FBK CONTATTORE	SPARE	FRENO SOLLEVAMENTO DX CTO. FBK CONTATTORE	FRENO SOLLEVAMENTO SX CTO. FBK CONTATTORE	FRENO TRASLAZIONE DX CTO. TERMICO MOTORE	FRENO TRASLAZIONE SX CTO. TERMICO MOTORE
		OK=1	OK=1	OK=1	OK=1	OK=1	OK=1	OK=1	OK=1

Card :1734-IB8 [8x10-30 Vdc DIGITAL INPUT]

Filo iniziale: 305.1
Filo finale: 305.8
Fili disponibili dal: 305.9

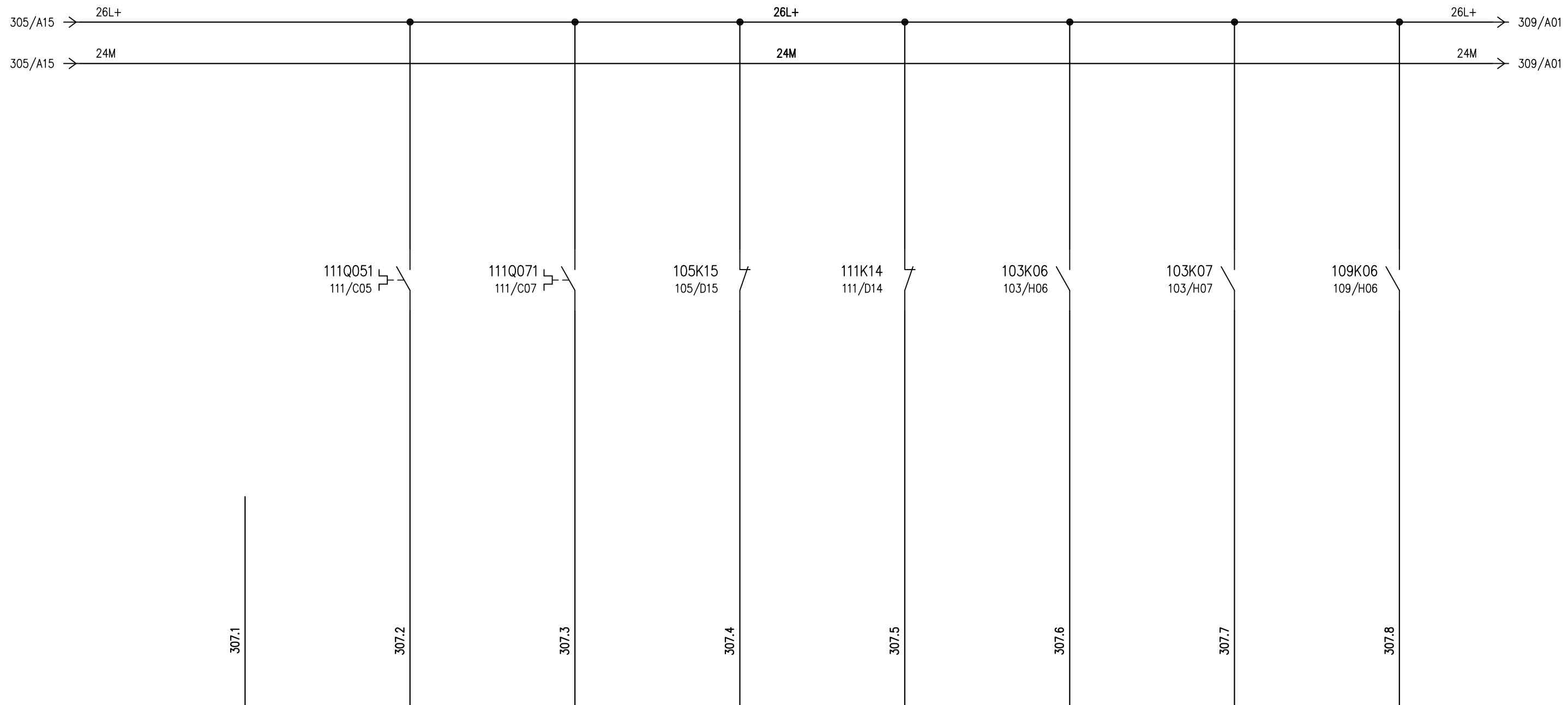

307A03	Pin	0	1	2	3	4	5	6	7
	Address	REMxx_3ID.0	REMxx_3ID.1	REMxx_3ID.2	REMxx_3ID.3	REMxx_3ID.4	REMxx_3ID.5	REMxx_3ID.6	REMxx_3ID.7
	Comment	...	FRENO SOLLEVAMENTO DX CTO. TERMICO MOTORE	FRENO SOLLEVAMENTO SX CTO. TERMICO MOTORE	INVERTER TRASLAZIONE INTERVENTO KLIXON RESISTENZA	INVERTER SOLLEVAMNETO INTERVENTO KLIXON RESISTENZA	INVERTER TRASLAZIONE IN MARCIA	INVERTER TRASLAZIONE IN FAULT	INVERTER SOLLEVAMENTO IN MARCIA
		OK=1	OK=1	OK=1	OK=1	OK=1	OK=1	OK=1	OK=1

Card :1734-IB8 [8x10-30 Vdc DIGITAL INPUT]

Filo iniziale: 307.1
 Filo finale: 307.8
 Fili disponibili dal: 307.9



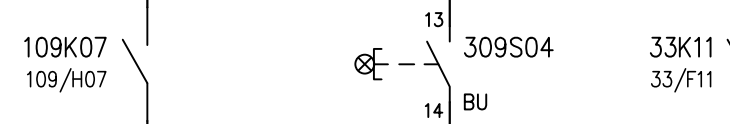
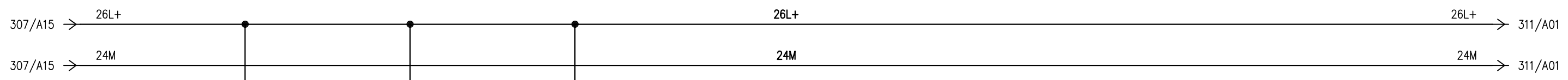

309A03	Pin	0	1	2	3	4	5	6	7
	Address	REMxx_4ID.0	REMxx_4ID.1	REMxx_4ID.2	REMxx_4ID.3	REMxx_4ID.4	REMxx_4ID.5	REMxx_4ID.6	REMxx_4ID.7
	Comment	...	INVERTER SOLLEVAMENTO IN FAULT	RESET ALLARMI	RELE MANCANZA FASE	LIBERO	LIBERO	LIBERO	LIBERO
			OK=1	OK=1	OK=1	OK=1	OK=1	OK=1	OK=1

Card :1734-IB8 [8x10-30 Vdc DIGITAL INPUT]

Filo iniziale: 309.1
 Filo finale: 309.8
 Fili disponibili dal: 309.9

REV.	MODIFICA	DATA	FIRMA	APPR.	DATA	04/03/2024		INGRESSI DIGITALI	REMOTO CARRO TRASFERITORE CC2	ACCIAIERIA		
					DISEG.	D.BILLE					NUM_ARCH:	EAAC0745
					VISTO						A348	A348.DWG
					SOST. IL:		SOST. DA:		ORIGINE:	PREC. SEG.		

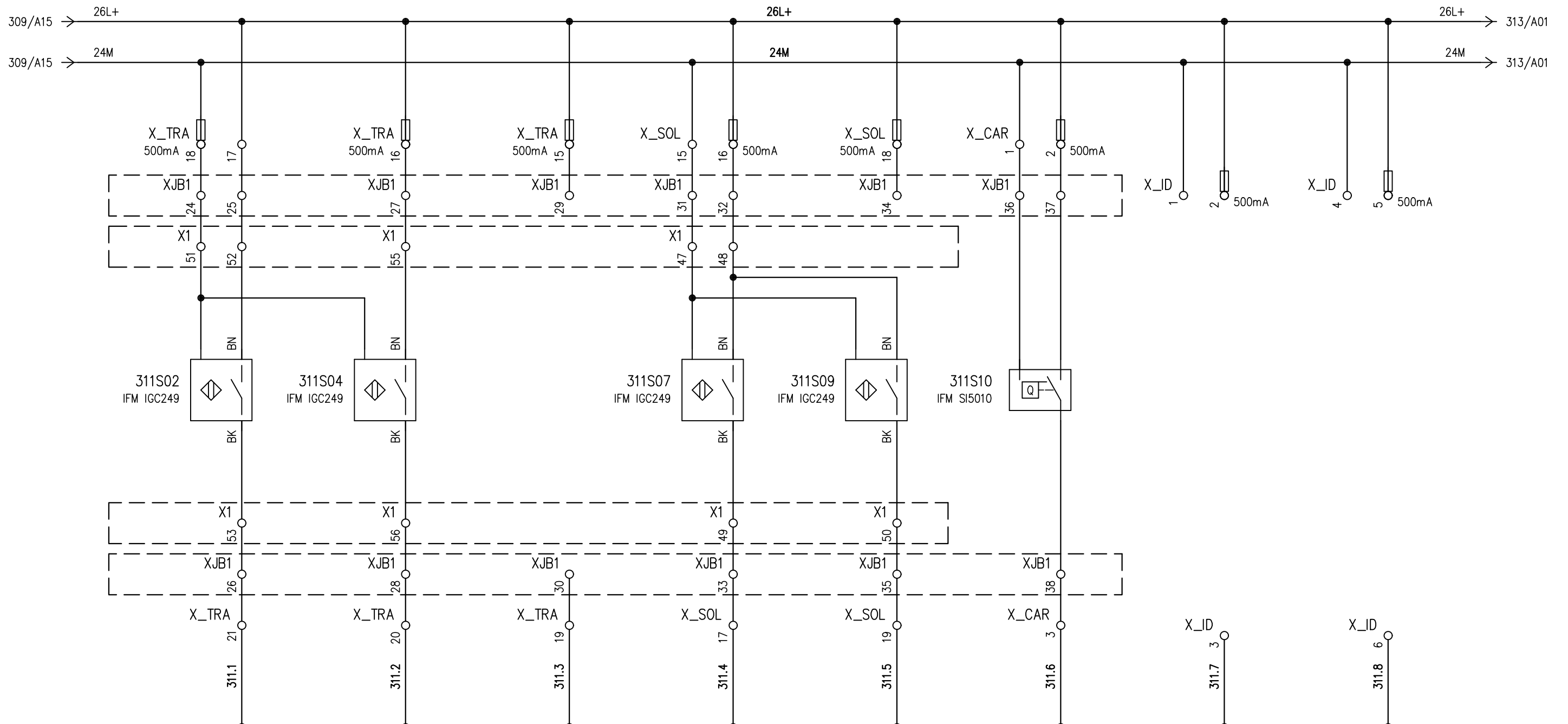

Pin	Address	Comment
0	REMxx_5ID.0	TRASLAZIONE DX FBK FRENO APERTO
1	REMxx_5ID.1	TRASLAZIONE SX FBK FRENO APERTO
2	REMxx_5ID.2	SPARE
3	REMxx_5ID.3	SOLLEVAMENTO DX FBK FRENO APERTO
4	REMxx_5ID.4	SOLLEVAMENTO SX FBK FRENO APERTO
5	REMxx_5ID.5	FLUSSOSTATO ARIA RAFFRED.
6	REMxx_5ID.6	SPARE
7	REMxx_5ID.7	SPARE
		OK=1

Card :1734-IB8 [8x10-30 Vdc DIGITAL INPUT]

Filo iniziale: 311.1
Filo finale: 311.8
Fili disponibili dal: 311.9

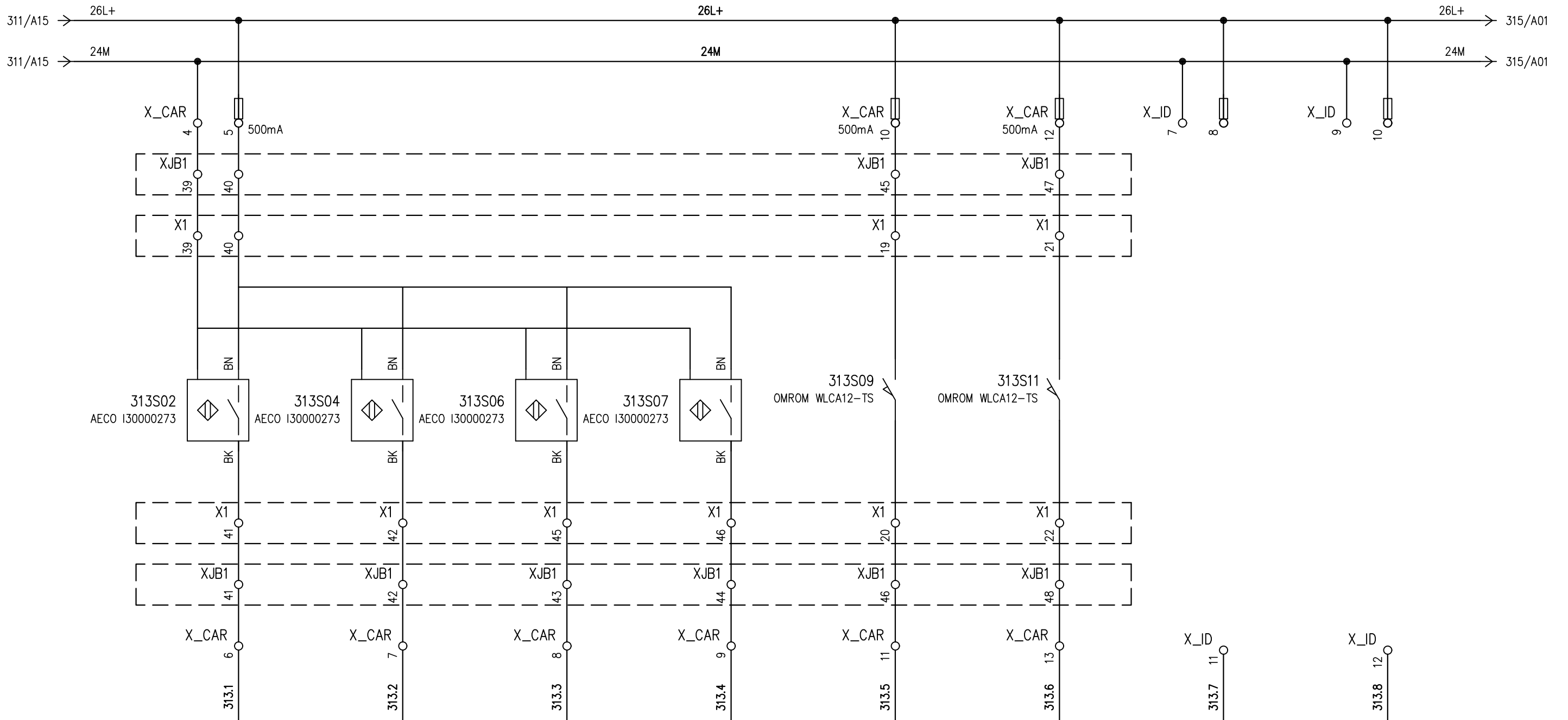

Pin	Address	Comment
0	REMxx_6ID.0	FC SOLLEVAMENTO FC PRESA OK=1
1	REMxx_6ID.1	FC SOLLEVAMENTO FC PRERAL. PRESA OK=1
2	REMxx_6ID.2	FC SOLLEVAMENTO FC RILASCIO OK=1
3	REMxx_6ID.3	FC SOLLEVAMENTO FC PRERAL. RILASCIO OK=1
4	REMxx_6ID.4	ACCESSO AL CARRO FC PASSERELLA LATO UFF. OK=1
5	REMxx_6ID.5	ACCESSO AL CARRO FC PASSERELLA LATO AUT. OK=1
6	REMxx_6ID.6	LIBERO OK=1
7	REMxx_6ID.7	LIBERO OK=1

Card :1734-IB8 [8x10-30 Vdc DIGITAL INPUT]

Filo iniziale: 313.1
Filo finale: 313.8
Fili disponibili dal: 313.9

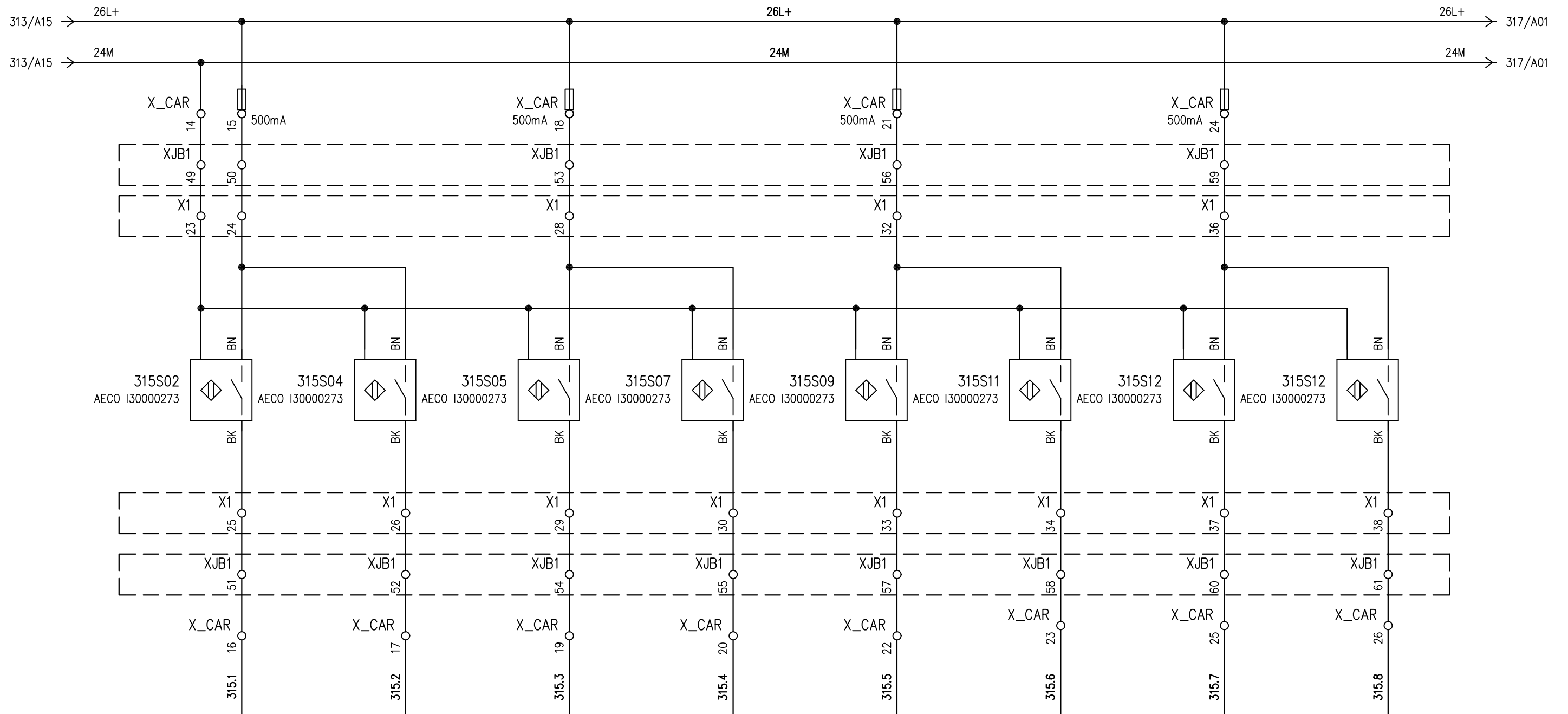

315A03	Pin	0	1	2	3	4	5	6	7
	Address	REMxx_7ID.0	REMxx_7ID.1	REMxx_7ID.2	REMxx_7ID.3	REMxx_7ID.4	REMxx_7ID.5	REMxx_7ID.6	REMxx_7ID.7
	Comment	LATO LAM/UFF SENSORE CARRO SU ROTAIA INT	LATO LAM/UFF SENSORE CARRO SU ROTAIA EXT	LATO FIUME/UFF SENSORE CARRO SU ROTAIA INT	LATO FIUME/UFF SENSORE CARRO SU ROTAIA EXT	LATO LAM/AUT SENSORE CARRO SU ROTAIA INT	LATO LAM/AUT SENSORE CARRO SU ROTAIA EXT	LATO FIUME/AUT SENSORE CARRO SU ROTAIA INT	LATO FIUME/AUT SENSORE CARRO SU ROTAIA EXT
		OK=1	OK=1	OK=1	OK=1	OK=1	OK=1	OK=1	OK=1

Card :1734-IB8 [8x10-30 Vdc DIGITAL INPUT]

Filo iniziale: 315.1
Filo finale: 315.8
Fili disponibili dal: 315.9

REV.	MODIFICA	DATA	FIRMA	APPR.	SOST. IL:	SOST. DA:	ORIGINE:	INGRESSI DIGITALI	REMOTO CARRO TRASFERITORE CC2	ACCIAIERIA
										NUM_ARCH: EAAC0745
								A348	A348.DWG	FOGLIO 315 DI
										PREC. SEG.



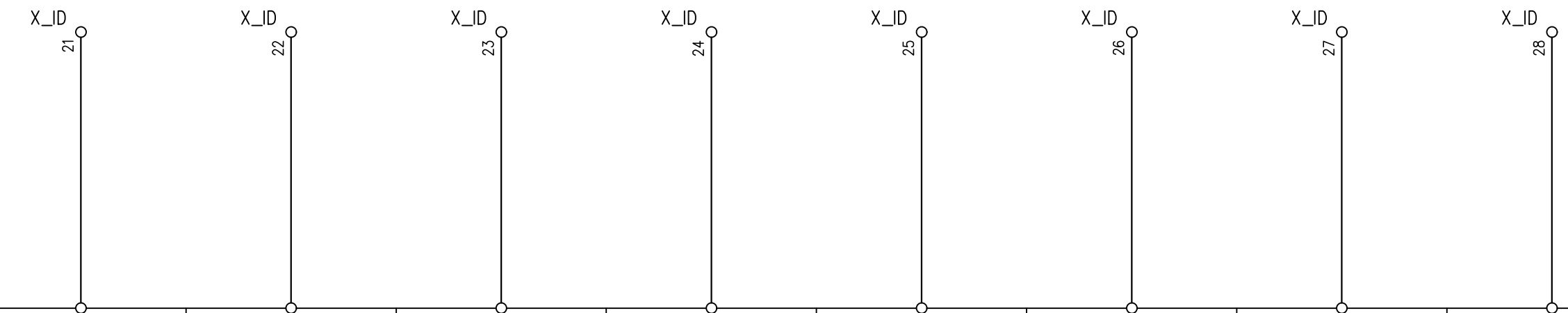
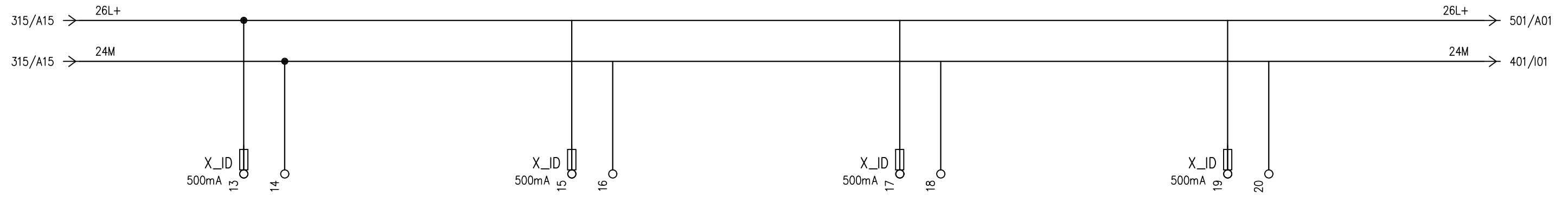

317A03	Pin	0	1	2	3	4	5	6	7
	Address	REMxx_8ID.0	REMxx_8ID.1	REMxx_8ID.2	REMxx_8ID.3	REMxx_8ID.4	REMxx_8ID.5	REMxx_8ID.6	REMxx_8ID.7
	Comment	LIBERO	LIBERO	LIBERO	LIBERO	LIBERO	LIBERO	LIBERO	LIBERO
		OK=1	OK=1	OK=1	OK=1	OK=1	OK=1	OK=1	OK=1

Card :1734-IB8 [8x10-30 Vdc DIGITAL INPUT]



Card :1734-OB8 [8x10-30Vdc DIGITAL OUTPUT]

401A03

Comment	TRASLAZIONE MARCIA AVANTI INVERTER	TRASLAZIONE MARCIA INDIETRO INVERTER	RESET EMERGENZA	TRASLAZIONE ENABLE INVERTER	SOLLEVAMENTO DIREZIONE PRESA INVERTER	SOLLEVAMENTO DIREZIONE RILASCIO INVERTER	RESET INVERTER	SOLLEVAMENTO ENABLE INVERTER
Address			REMxx_90D.0	REMxx_90D.1	REMxx_90D.2	REMxx_90D.3	REMxx_90D.4	REMxx_90D.5	REMxx_90D.6	REMxx_90D.7
Pin			0	1	2	3	4	5	6	7

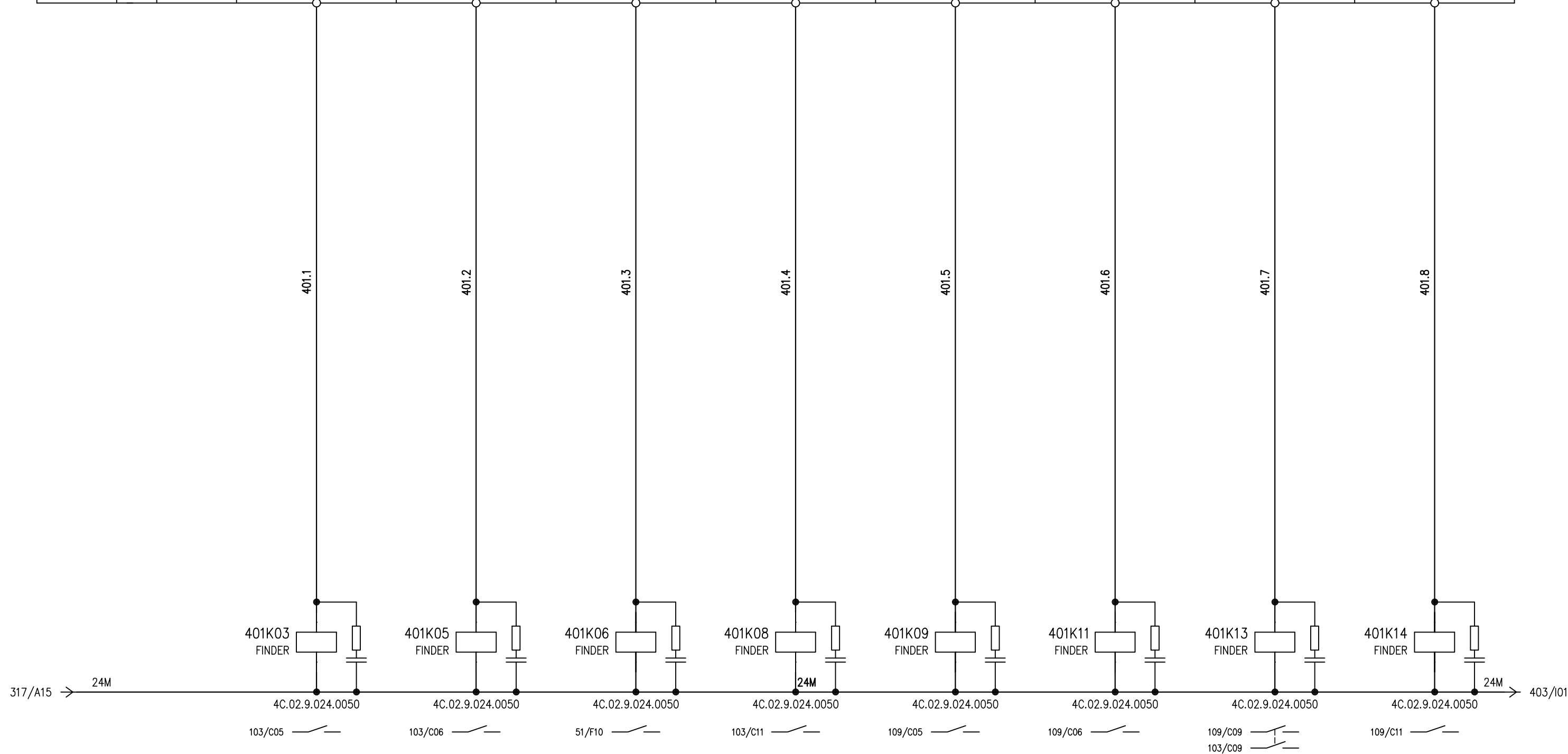

Filo iniziale: 401.1
 Filo finale: 401.8
 Fili disponibili dal: 401.9

DATA	04/03/2024		USCITE DIGITALI		REMOTO CARRO TRASFERITORE CC2	ACCIAIERIA			
DISEG.	D.BILLE					NUM_ARCH: EAAC0745			
VISTO					A348	A348.DWG	FOGLIO 401 DI		
REV.	MODIFICA	DATA	FIRMA	APPR.	SOST. IL:	SOST. DA:	ORIGINE:	PREC.	SEG.

Card :1734-OB8 [8x10-30Vdc DIGITAL OUTPUT]

405A03

Comment	LIBERO	LIBERO	LIBERO	LIBERO	LIBERO	LIBERO	LIBERO	LIBERO
Address			REMxx_11OD.0	REMxx_11OD.1	REMxx_11OD.2	REMxx_11OD.3	REMxx_11OD.4	REMxx_11OD.5	REMxx_11OD.6	REMxx_11OD.7
Pin			0	1	2	3	4	5	6	7

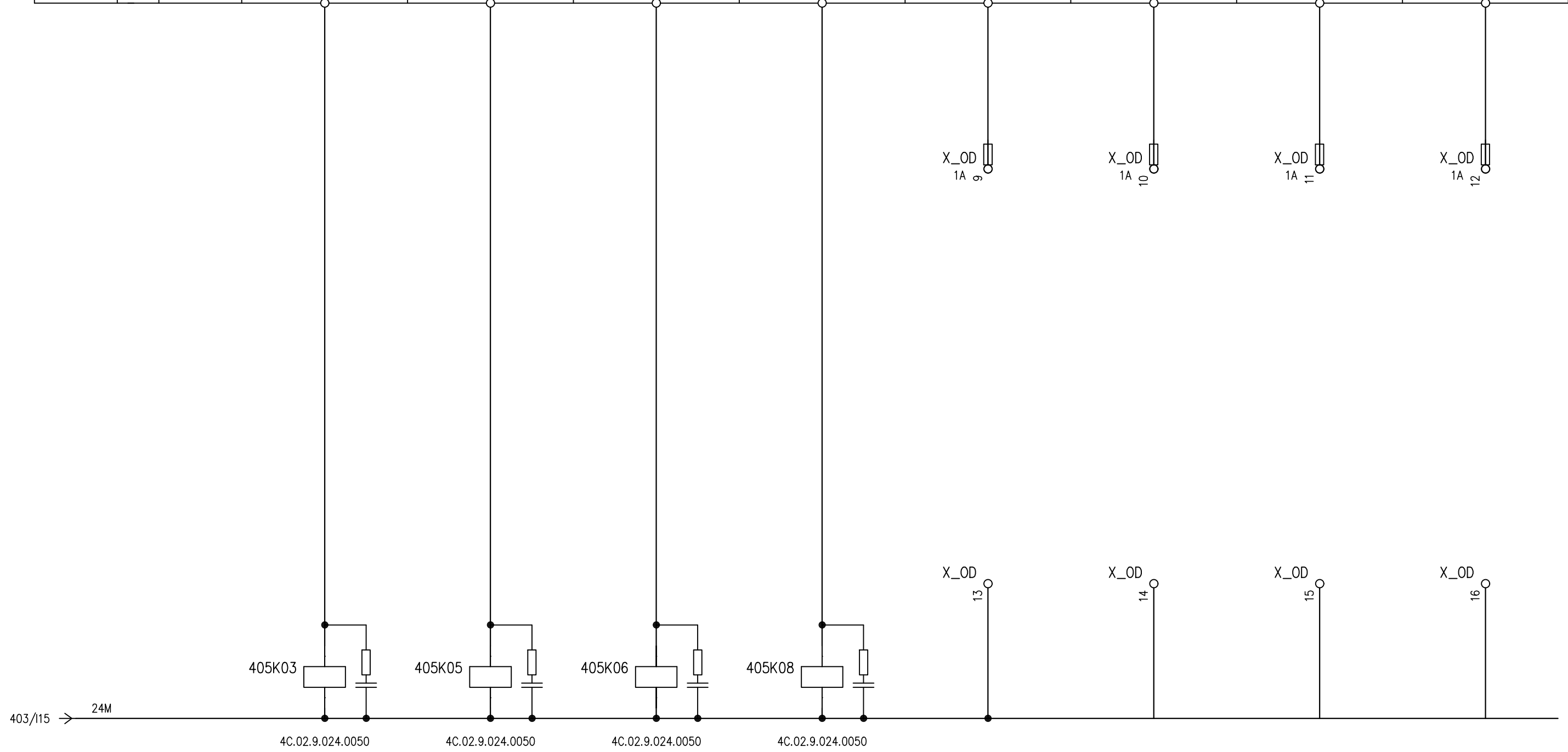

REV.	MODIFICA	DATA	FIRMA	APPR.	DATA	04/03/2024		USCITE DIGITALI	REMOTO CARRO TRASFERITORE CC2	ACCIAIERIA NUM_ARCH: EAAC0745
					DISEG.	D.BILLE				
					VISTO					
					SOST. IL:	SOST. DA:	ORIGINE:	A348	A348.DWG	FOGLIO 405 DI PREC. SEG.

A
B
C
D
E
F
G
H
I
J

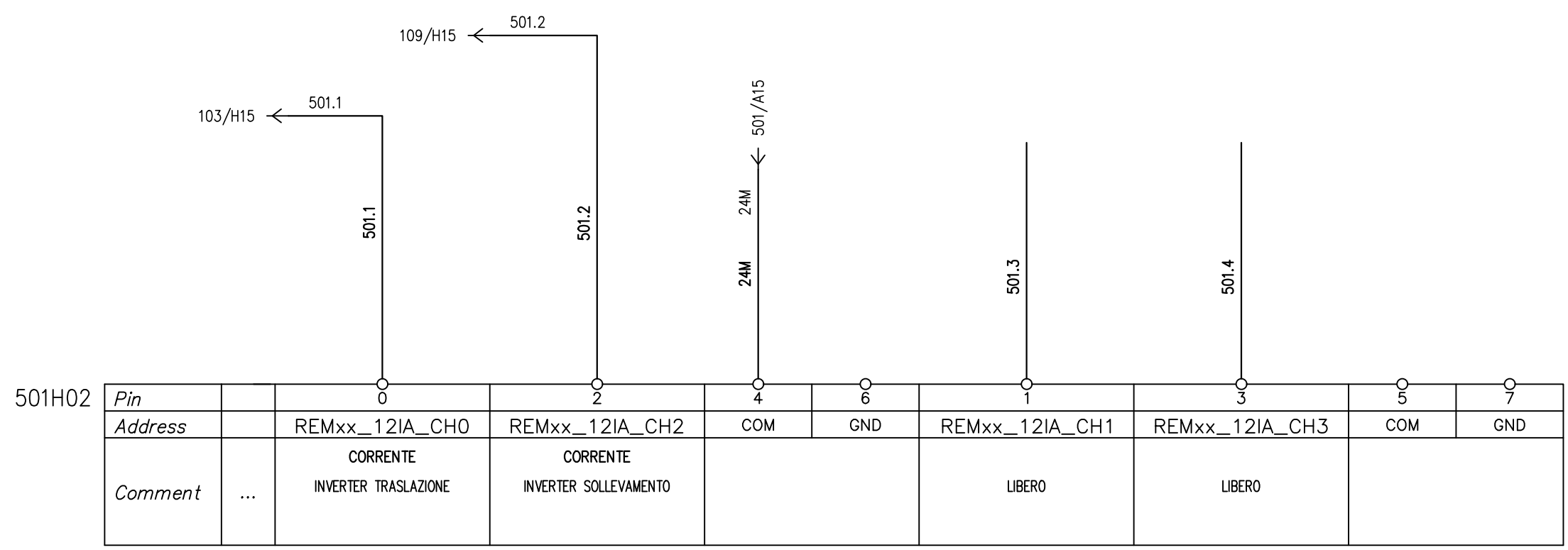
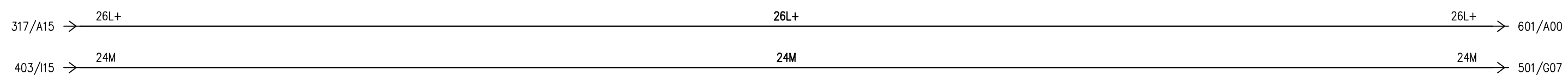

Card :1734-IE4C [4x ANALOG CURRENT INPUT]

Filo iniziale: 501.1
 Filo finale: 501.4
 Fili disponibili dal: 501.5

REV.	MODIFICA	DATA	FIRMA	APPR.	SOST. IL:	SOST. DA:	ORIGINE:	INGRESSI ANALOGICI	REMOTO CARRO TRASFERITORE CC2	ACCIAIERIA
		04/03/2024								NUM_ARCH: EAAC0745
									A348	FOGLIO 501 DI
									A348.DWG	PREC. SEG.



Card :1734-OE4C [4x4-20mA Analog Output]

551A03

Comment	RIF. VELOCITA' TRASLAZIONE	RIF. VELOCITA' SOLLEVAMNETO	LIBERO	LIBERO				
Address			REMxx_130A_CHO	REMxx_130A_CH1	REMxx_130A_CH2	REMxx_130A_CH3	COMMON	COMMON	SUPPLY	SUPPLY
Pin			0	1	2	3	4	5	6	7

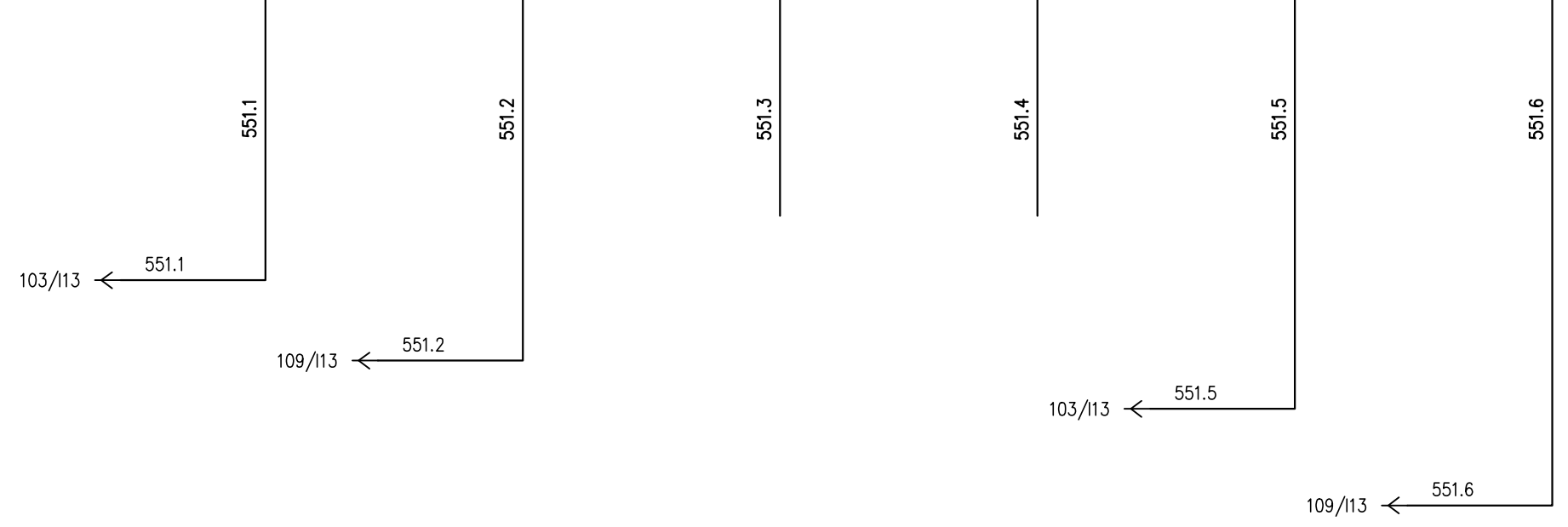

Filo iniziale: 551.1
Filo finale: 551.6
Fili disponibili dal: 551.7

DATA	04/03/2024		USCITE ANALOGICHE		REMOTO CARRO TRASFERITORE CC2	ACCIAIERIA						
DISEG.	D.BILLE					NUM_ARCH: EAAC0745						
VISTO					A348	A348.DWG	FOGLIO 551 DI					
REV.	MODIFICA	DATA	FIRMA	APPR.	SOST. IL:	SOST. DA:	ORIGINE:				PREC.	SEG.

A
B
C
D
E
F
G
H
I
J

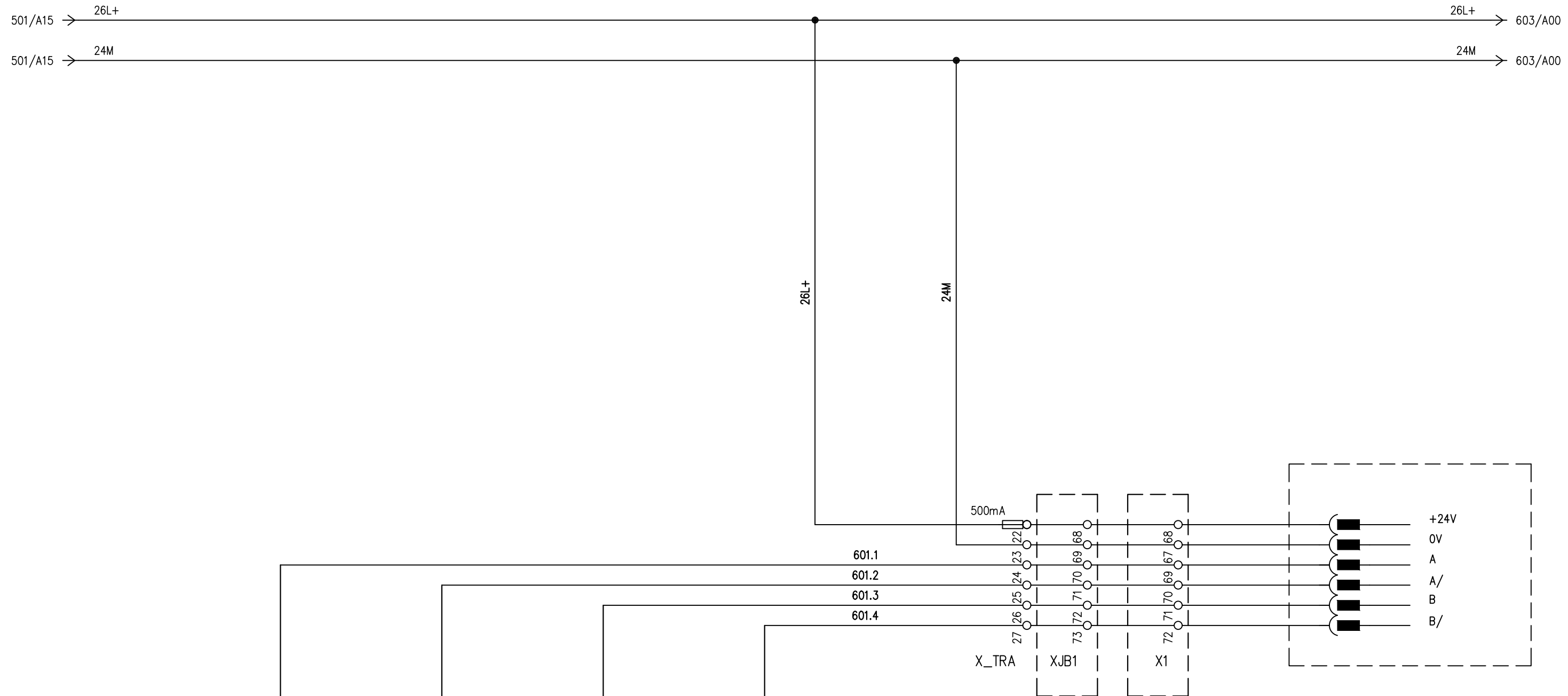

601A02	Pin		0	1	2	3	4	5	6	7
	Address		REMxx_14HSC	REMxx_14HSC	REMxx_14HSC	REMxx_14HSC	REMxx_14HSC	REMxx_14HSC	REMxx_14HSC	REMxx_14HSC
	Comment	...	CANALE A	CANALE A/	CANALE B	CANALE B/	CANALE Z	CANALE Z/	GND CHASSIS	GND CHASSIS
			OK=1	OK=1	OK=1	OK=1	OK=1	OK=1	OK=1	OK=1

Card :1734-1K [15-24 Vdc ENCODER/COUNTER Module]

Filo iniziale: 601.1
Filo finale: 601.4
Fili disponibili dal: 601.5

				DATA	04/03/2024	AFV ACCIAIERIE BELTRAME S.p.a.	ENCODER TRASLAZIONE	REMOTO CARRO TRASFERITORE CC2	ACCIAIERIA		
				DISEG.	D.BILLE				NUM_ARCH: EAAC0745		
				VISTO					FOGLIO 601 DI		
REV.	MODIFICA	DATA	FIRMA	APPR.		SOST. IL:	SOST. DA:	ORIGINE:	A348	A348.DWG	PREC. SEG.

A
B
C
D
E
F
G
H
I
J

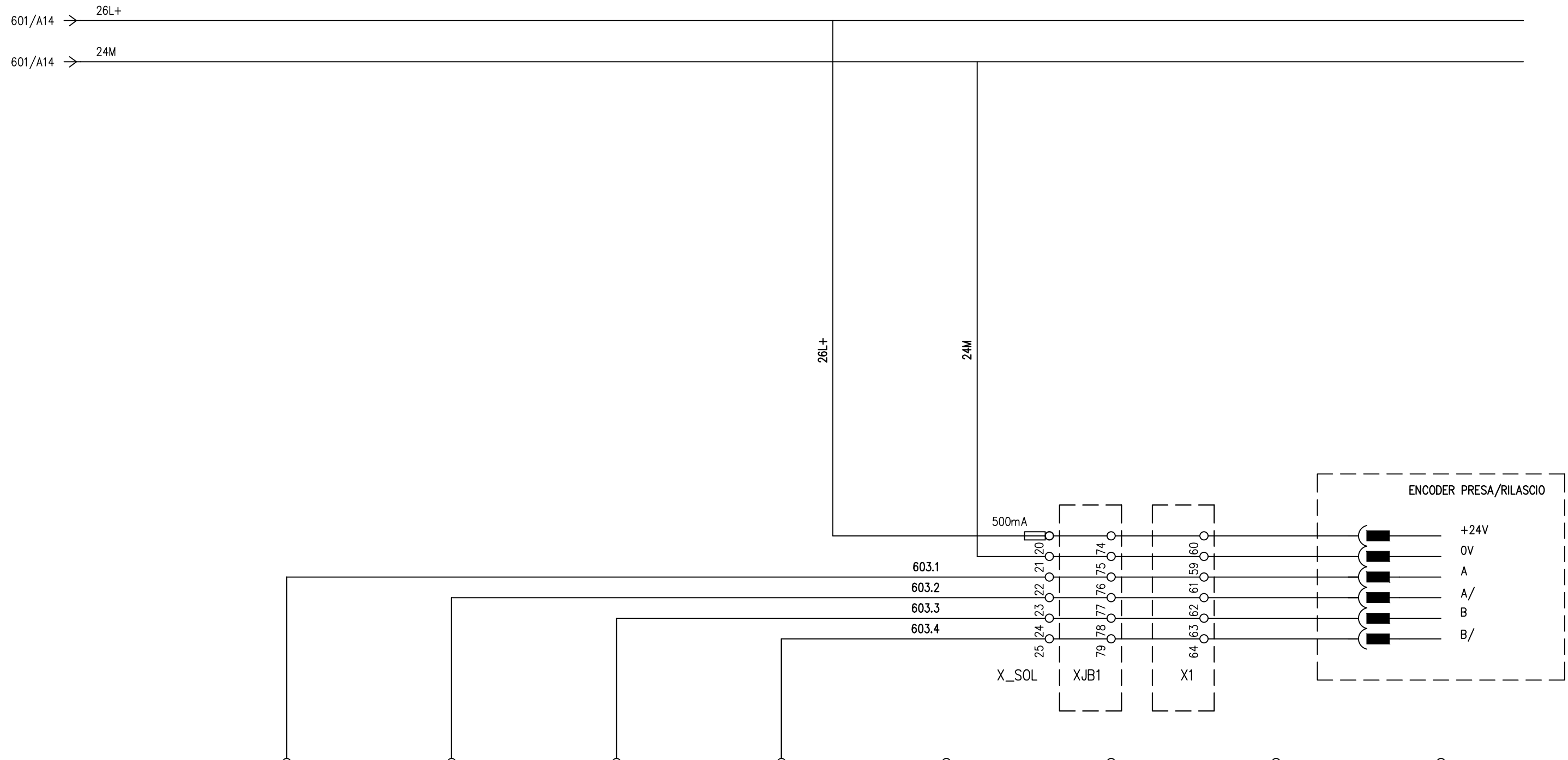

603A02	Pin		0	1	2	3	4	5	6	7
	Address		REMxx_15HSC	REMxx_15HSC	REMxx_15HSC	REMxx_15HSC	REMxx_15HSC	REMxx_15HSC	REMxx_15HSC	REMxx_15HSC
	Comment	...	CANALE A	CANALE A/	CANALE B	CANALE B/	CANALE Z	CANALE Z/	GND CHASSIS	GND CHASSIS
			OK=1	OK=1	OK=1	OK=1	OK=1	OK=1	OK=1	OK=1

Card :1734-1K [15-24 Vdc ENCODER/COUNTER Module]

Filo iniziale: 603.1
Filo finale: 603.4
Fili disponibili dal: 603.5

				DATA	04/03/2024	AFV ACCIAIERIE BELTRAME S.p.a.	ENCODER SOLLEVAMENTO	REMOTO CARRO TRASFERITORE CC2	ACCIAIERIA		
				DISEG.	D.BILLE				NUM_ARCH: EAAC0745		
				VISTO					FOGLIO 603 DI		
REV.	MODIFICA	DATA	FIRMA	APPR.		SOST. IL:	SOST. DA:	ORIGINE:	A348	A348.DWG	PREC. SEG.

